

ZÁVITNÍKY  
TAPS  
GEWINDEBOHRER  
МЕТЧИКИ

M

MF

BSW (W)

G

Pg

UNC

UNF



**BUČOVICE**  
**TOOLS a.s.**

# ZÁVITNÍKY TAPS GEWINDEBOHRER МЕТЧИКИ

<b>M</b>	<b>M</b>	<b>M</b>	<b>M</b>	<b>M</b>	<b>M</b>
<b>MF</b>	<b>MF</b>	<b>MF</b>	<b>MF</b>	<b>MF</b>	
<b>G</b>	<b>G</b>	<b>G</b>			
<b>BSW (W)</b>	<b>BSW (W)</b>				
<b>Pg</b>	<b>UNC</b>				
<b>UNC</b>	<b>UNF</b>				
<b>UNF</b>					

Norma / Standard / Norm / Стандарт

ČSN 22 3010 DIN 352 DIN 2181 BSW 8/3011 ČSN 22 3012 PN 8/3014	ČSN 22 3010 DIN 352 DIN 2181 BSW 8/3011 ČSN 22 3012 PN 8/3016 DIN 5157 ISO 529	ČSN 22 3062 ČSN 22 3064 ČSN 22 3070 ČSN 22 3074	ČSN 22 3070 ČSN 22 3074	DIN 371 (2N) DIN 374 (2N) DIN 376 (2N)	DIN 371 (ISO2) DIN 376 (ISO2) ČSN 223042 (ISO1) ČSN 223043 (ISO1) PN 8/3044 (ISO1)
--	---	--	----------------------------	--	--

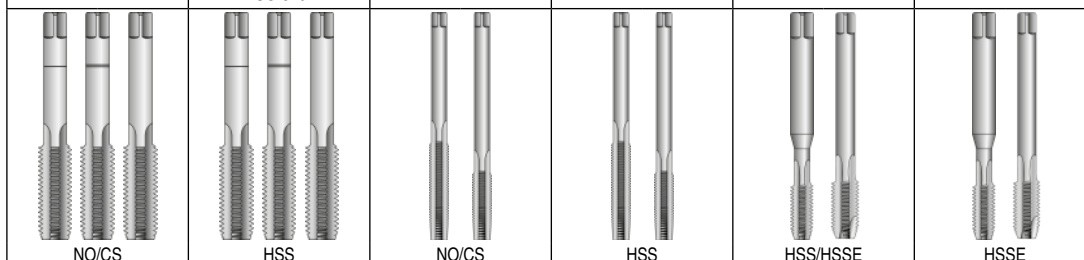

NO/CS	HSS	NO/CS	HSS	HSS/HSSE	HSSE	
$v_c$ [m/min]	$v_c$ [m/min]	$v_c$ [m/min]	$v_c$ [m/min]	$v_c$ [m/min]	$v_c$ [m/min]	

<b>P</b>	1	4 - 7	6 - 10	4 - 7	6 - 10	6 - 10	8 - 15	O/E
	2	2 - 5	3 - 8		5 - 8	5 - 8	6 - 10	O/E
	3	4 - 7	6 - 10	4 - 7	6 - 10	6 - 10	6 - 10	O/E
	4		2 - 6			3 - 6	4 - 8	O
	5							
	6	1 - 4	2 - 6		2 - 6	5 - 8	6 - 10	O/E
	7	1 - 3	2 - 4			4 - 6	5 - 8	O/E
<b>M</b>	1						2 - 4	O
	2							
<b>K</b>	1	1 - 3	2 - 4			5 - 8	5 - 8	O
	2	1 - 4	2 - 6			3 - 6	3 - 6	O
	3	1 - 4	2 - 6			5 - 8	5 - 8	O/E
<b>N</b>	1	2 - 4	3 - 8			5 - 8	5 - 8	O/E
	2	8 - 12	10 - 16	8 - 12	12 - 18	12 - 18	12 - 18	O/E
	3	4 - 7	6 - 10	4 - 7	6 - 10	6 - 10	6 - 10	O/E
	4					5 - 8	5 - 8	O/E
	5	5 - 10	10 - 16			10 - 15	10 - 15	O/P/E
	6	5 - 10	10 - 16			10 - 15	10 - 15	O/E
	7	5 - 15	10 - 20		10 - 20	10 - 20	10 - 20	V/O/E
	8	5 - 10	8 - 15		8 - 15	8 - 15	8 - 15	V/O/E
<b>S</b>								
<b>H</b>	1							
	2							
	3							

○ Omezené použití / Possible use / Geeignet / Ограниченно  
● Doporučené použití / Optimal use / Optimal / Оптимально

**BUČOVICE**  
TOOLS a.s.

# ČSN 22 3010

NO

HSS

## Závitníky sadové Set of hand taps Satzgewindebohrer Метчики наборные

**M**  
Metrický závit  
Standard metric thread  
Metrische Regelgewinde  
Метрическая резьба

**MF**  
Jemný metrický závit  
Fine metric thread  
Metrische Feingewinde  
Мелкая метрическая резьба

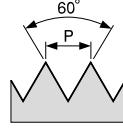
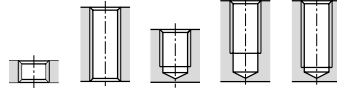

Lícování: 2N / Tolerance: 2N /  
Toleranz: 2N / Подгонка: 2N

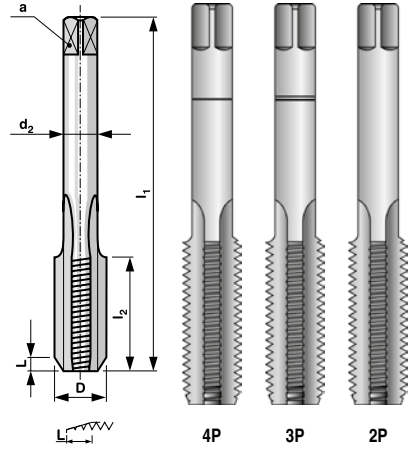

D	P	l <sub>1</sub>	l <sub>2</sub>	d <sub>2</sub>	a		*	code NO/CS	code HSS	code NO/CS - LH	code HSS - LH
M 2	0,4	34	8	2,5	2	1,60	3	110 020	140 020	120 020	150 020
M 2,2	0,45	34	9	2,8	2,24	1,75	3	110 022	140 022		
M 2,5	0,45	34	10	2,8	2,24	2,05	3	110 025	140 025		
M 2,5	0,35	28	8	2,8	2,24	2,15	2	110 026	140 026		
M 3	0,5	36	10	3,15	2,5	2,50	3	110 030	140 030	120 030	150 030
M 3	0,35	32	8	3,15	2,5	2,65	2	110 031	140 031		
M 3,5	0,6	36	12	3,55	2,8	2,90	3	110 035	140 035		
M 3,5	0,35	32	9	3,55	2,8	3,15	2	110 036	140 036		
M 4	0,7	41	14	4	3,15	3,30	3	110 040	140 040	120 040	150 040
M 4	0,5	38	11	4	3,15	3,50	2	110 041	140 041		
M 4,5	0,5	38	11	4,5	3,55	4,00	2	110 046	140 046		
M 5	0,8	45	16	5	4	4,20	3	110 050	140 050	120 050	150 050
M 5	0,5	40	11	5	4	4,50	2	110 051	140 051		
M 5,5	0,5	40	12	5,6	4,5	5,00	2	110 056	140 056		
M 6	1	50	17	4,5	3,55	5,00	3	110 060	140 060	120 060	150 060
M 6	0,75	44	15	4,5	3,55	5,20	2	110 061	140 061		
M 7	1	50	17	5,6	4,5	6,00	3	110 070	140 070	120 070	150 070
M 7	0,75	44	15	5,6	4,5	6,20	2	110 071	140 071		
M 8	1,25	54	22	6	5	6,80	3	110 080	140 080	120 080	150 080
M 8	1	46	16	6	5	7,00	2	110 081	140 081		
M 8	0,75	44	16	6	5	7,20	2	110 082	140 082		
M 9	1,25	60	22	7,1	5,6	7,80	3	110 090	140 090	120 090	150 090
M 9	1	52	17	7,1	5,6	8,00	2	110 091	140 091		
M 9	0,75	50	17	7,1	5,6	8,20	2	110 092	140 092		
M 10	1,5	63	25	7,1	5,6	8,50	3	110 100	140 100	120 100	150 100
M 10	1,25	56	18	7,1	5,6	8,80	2	110 101	140 101		
M 10	1	56	18	7,1	5,6	9,00	2	110 102	140 102		
M 10	0,75	56	18	7,1	5,6	9,20	2	110 103	140 103		
M 11	1,5	63	28	8	6,3	9,50	3	110 110	140 110	120 110	150 110
M 11	1	56	20	8	6,3	10,00	2	110 111	140 111		
M 11	0,75	56	20	8	6,3	10,20	2	110 112	140 112		
M 12	1,75	70	30	9	7,1	10,20	3	110 120	140 120	120 120	150 120
M 12	1,5	63	25	9	7,1	10,50	2	110 121	140 121		
M 12	1,25	60	22	9	7,1	10,80	2	110 122	140 122		
M 12	1	60	22	9	7,1	11,00	2	110 123	140 123		
M 14	2	80	30	11	9	12,00	3	110 140	140 140	120 140	150 140
M 14	1,5	70	28	11	9	12,50	2	110 141	140 141		
M 14	1,25	63	25	11	9	12,80	2	110 142	140 142		
M 14	1	63	25	11	9	13,00	2	110 143	140 143		
M 15	1	70	25	11	9	14,00	2	110 152	140 152		
M 16	2	80	35	12,5	10	14,00	3	110 160	140 160	120 160	150 160
M 16	1,5	70	28	12,5	10	14,50	2	110 161	140 161		
M 16	1	70	25	12,5	10	15,00	2	110 162	140 162		
M 17	1	70	28	12,5	10	16,00	2	110 171	140 171		
M 18	2,5	90	36	14	11,2	15,50	3	110 180	140 180	120 180	150 180
M 18	1,5	80	32	14	11,2	16,50	2	110 181	140 181		
M 18	1	70	28	14	11,2	17,00	2	110 182	140 182		
M 20	2,5	90	36	14	11,2	17,50	3	110 200	140 200	120 200	150 200
M 20	1,5	80	32	14	11,2	18,50	2	110 201	140 201		
M 20	1	75	28	14	11,2	19,00	2	110 202	140 202		
M 22	2,5	90	40	16	12,5	19,50	3	110 220	140 220	120 220	150 220
M 22	1,5	80	32	16	12,5	20,50	2	110 221	140 221		
M 22	1	75	28	16	12,5	21,00	2	110 222	140 222		
M 24	3	100	45	18	14	21,00	3	110 240	140 240	120 240	150 240
M 24	2	90	36	18	14	22,00	2	110 241	140 241		
M 24	1,5	85	32	18	14	22,50	2	110 242	140 242		
M 24	1	80	28	18	14	23,00	1	110 243	140 243		
M 25	1,5	90	32	18	14	23,50	2	110 252	140 252		
M 26	1,5	90	32	18	14	24,50	2	110 262	140 262		
M 27	3	100	45	20	16	24,00	3	110 270	140 270	120 270	150 270



**BUČOVICE TOOLS a.s.**

Materiál: NO; HSS  
Provedení: nebroušený závit  
Závit: pravý,  
levý - dle požadavku

Material: CS; HSS  
Execution: non-ground thread  
Thread: right-hand, left-hand  
on request

Werkstoff: WS; HSS  
Ausführung: nicht  
geschliffenes Gewinde  
Gewinde: rechts, links - nach  
dem Anspruch

Материал: NO; HSS  
Изготовлено:  
нешлифованная резьба  
Резьба: правая,  
левая - по заказу

# ČSN 22 3010

## NO

## HSS

### Závitníky sadové Set of hand taps Satzgewindebohrer Метчики наборные

**M**  
Metrický závit  
Standard metric thread  
Metrische Regelgewinde  
Метрическая резьба

**MF**  
Jemný metrický závit  
Fine metric thread  
Metrische Feingewinde  
Мелкая метрическая резьба

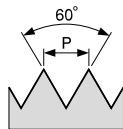
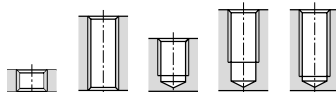

Lícování: 2N / Tolerance: 2N /  
Toleranz: 2N / Подгонка: 2N

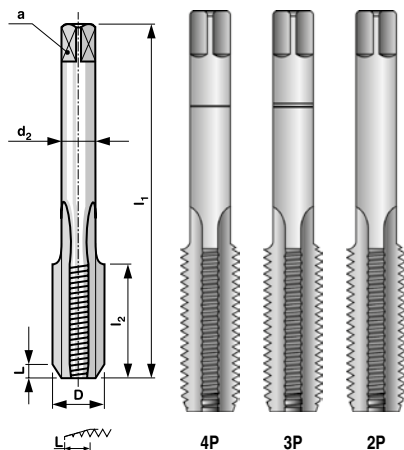

D	P	l <sub>1</sub>	l <sub>2</sub>	d <sub>2</sub>	a		*	code NO/CS	code HSS	code NO/CS - LH	code HSS - LH
M 27	2	90	36	20	16	25,00	2	110 271	140 271		
M 27	1,5	90	32	20	16	25,50	2	110 272	140 272		
M 27	1	85	28	20	16	26,00	1	110 273	140 273		
M 28	2	100	36	20	16	26,00	2	110 281	140 281		
M 28	1,5	90	32	20	16	26,50	2	110 282	140 282		
M 30	3,5	120	50	20	16	26,50	3	110 300	140 300		
M 30	2	100	36	20	16	28,00	2	110 301	140 301		
M 30	1,5	100	32	20	16	28,50	2	110 302	140 302		
M 30	1	85	32	20	16	29,00	1	110 303	140 303		

\* kusy v sadě / pcs in set / Stck in Satz / штук в наборе

Materiál: NO: HSS  
Provedení: nebroušený závit  
Závit: pravý,  
levý - dle požadavku

Material: CS: HSS  
Execution: non-ground thread  
Thread: right-hand, left-hand  
on request

Werkstoff: WS: HSS  
Ausführung: nicht  
geschliffenes Gewinde  
Gewinde: rechts, links - nach  
dem Anspruch

Материал: NO: HSS  
Изготовлено:  
нешлифованная резьба  
Резьба: правая,  
левая - по заказу

**BUČOVICE  
TOOLS a.s.**

# BSW - 8/3011

NO

HSS

**Závitníky sadové**  
**Set of hand taps**  
**Satzgewindebohrer**  
**Метчики наборные**

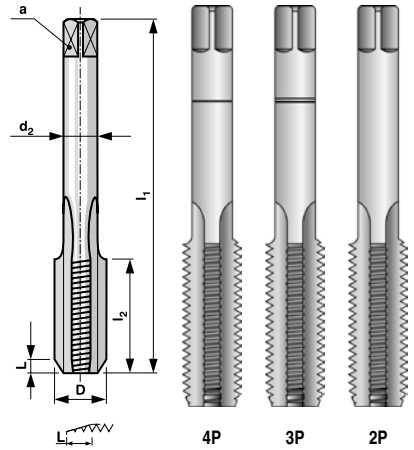
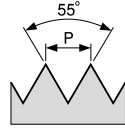
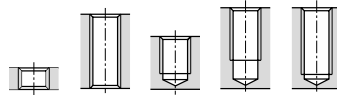

Lícování: střední / Tolerance: medium /  
 Toleranz: mittel / Подгонка: средний класс



Whitworthův závit  
 Whitworth thread  
 Whitworth-Gewinde  
 Резьба Витворта

D	z/1"	P	l <sub>1</sub>	l <sub>2</sub>	d <sub>2</sub>	a		*	code NO/CS	code HSS
BSW 3/32"	48	0,529	34	10	3,15	2,5	1,85	3	111 332	141 332
BSW 1/8"	40	0,635	37	12	4	3,15	2,55	3	111 180	141 180
BSW 5/32"	32	0,794	41	14	5	4	3,10	3	111 532	141 532
BSW 3/16"	24	1,058	44	18	5	4	3,60	3	111 316	141 316
BSW 7/32"	24	1,058	44	18	5,6	4,5	4,40	3	111 732	141 732
BSW 1/4"	20	1,270	48	22	6,3	5	5,10	3	111 140	141 140
BSW 5/16"	18	1,411	51	26	5,6	4,5	6,50	3	111 516	141 516
BSW 3/8"	16	1,588	60	26	7,1	5,6	7,90	3	111 380	141 380
BSW 7/16"	14	1,814	60	28	8	6,3	9,20	3	111 716	141 716
BSW 1/2"	12	2,117	70	32	9	7,1	10,50	3	111 120	141 120
BSW 9/16"	12	2,117	70	32	9	7,1	12,00	3	111 916	141 916
BSW 5/8"	11	2,309	80	36	12,5	10	13,50	3	111 580	141 580
BSW 3/4"	10	2,540	90	40	14	11,2	16,50	3	111 340	141 340
BSW 7/8"	9	2,822	100	45	18	14	19,25	3	111 780	141 780
BSW 1"	8	3,175	110	45	20	16	21,75	3	111 100	141 100

\* kusy v sadě / pcs in set / Stck in Satz / штук в наборе

# ČSN 22 3012

NO

HSS

**Závitníky sadové**  
**Set of hand taps**  
**Satzgewindebohrer**  
**Метчики наборные**

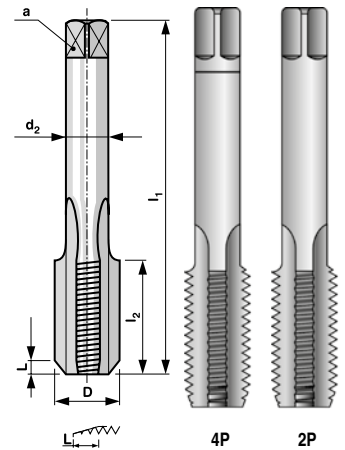
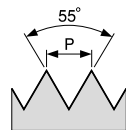
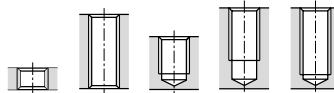

Lícování: A / Tolerance: A /  
 Toleranz: A / Подгонка: A



Trubkový závit  
 Pipe thread  
 Rohrgewinde  
 Трубная резьба

D	z/1"	P	l <sub>1</sub>	l <sub>2</sub>	d <sub>2</sub>	a		*	code NO/CS	code HSS
G 1/16"	28	0,907	52	14	5,6	4,5	6,80	2	112 116	142 116
G 1/8"	28	0,907	59	15	8	6,3	8,80	2	112 180	142 180
G 1/4"	19	1,337	67	19	10	8	11,80	2	112 140	142 140
G 3/8"	19	1,337	75	21	12,5	10	15,20	2	112 380	142 380
G 1/2"	14	1,814	87	26	16	12,5	19,00	2	112 120	142 120
G 5/8"	14	1,814	91	26	18	14	21,00	2	112 580	142 580
G 3/4"	14	1,814	96	28	20	16	24,50	2	112 340	142 340
G 7/8"	14	1,814	102	29	22,4	18	28,25	2	112 780	142 780
G 1"	11	2,309	109	33	25	20	30,75	2	112 100	142 100

\* kusy v sadě / pcs in set / Stck in Satz / штук в наборе



Materiál: NO; HSS  
 Provedení: nebroušený závit

Material: CS; HSS  
 Execution: non-ground thread

Werkstoff: WS; HSS  
 Ausführung: nicht geschliffenes Gewinde

Материал: NO; HSS  
 Изготовлено: нешлифованная резьба

# DIN 5157

HSS

HSSE  
OX VA

## Závitníky sadové Set of hand taps Satzgewindebohrer Метчики наборные

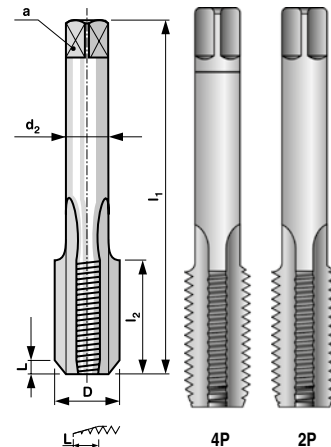
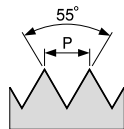
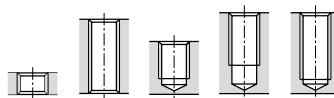

Lícování: A / Tolerance: A /  
Toleranz: A / Подгонка: A

G

Trubkový závit  
Pipe thread  
Rohrgewinde  
Трубная резьба

D	z/1"	P	l <sub>1</sub>	l <sub>2</sub>	d <sub>2</sub>	a		*	code HSS	code HSSE OX VA
G 1/16"	28	0,907	63	17	6	4,9	6,80	2	170 116	171 116
G 1/8"	28	0,907	63	18	7	5,5	8,80	2	170 180	171 180
G 1/4"	19	1,337	70	20	11	9	11,80	2	170 140	171 140
G 3/8"	19	1,337	70	20	12	9	15,20	2	170 380	171 380
G 1/2"	14	1,814	80	22	16	12	19,00	2	170 120	171 120
G 5/8"	14	1,814	80	22	18	14,5	21,00	2	170 580	171 580
G 3/4"	14	1,814	90	22	20	16	24,50	2	170 340	171 340
G 7/8"	14	1,814	90	22	22	18	28,25	2	170 780	171 780
G 1"	11	2,309	100	25	25	20	30,75	2	170 100	171 100
G 1 1/8"	11	2,309	125	30	28	22	35,50	2	170 118	
G 1 1/4"	11	2,309	125	30	32	24	39,50	2	170 114	
G 1 3/8"	11	2,309	125	30	36	29	41,80	2	170 138	
G 1 1/2"	11	2,309	140	30	36	29	45,25	2	170 112	
G 1 3/4"	11	2,309	140	32	40	32	51,30	2	170 134	
G 2"	11	2,309	160	36	45	35	57,20	2	170 200	

\* kusy v sadě / pcs in set / Stck in Satz / штук в наборе

Materiál: HSS; HSSE  
Provedení: broušený závit

Material: HSS, HSSE  
Execution: ground thread

Werkstoff: HSS, HSSE  
Ausführung: geschliffenes  
Gewinde

Материал: HSS, HSSE  
Изготовлено: шлифованная  
резьба

# PN 8/3014

NO

## Závitníky sadové Set of hand taps Satzgewindebohrer Метчики наборные

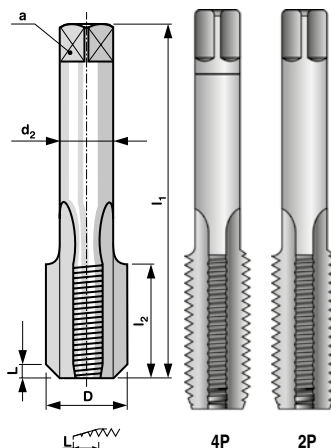
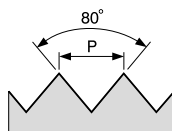
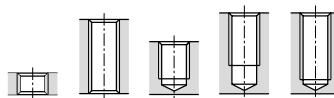

Pg

Pancéřový závit  
Steel conduit thread  
Stahlpanzerrohr-Gewinde  
Панцирная резьба

D	z/1"	P	l <sub>1</sub>	l <sub>2</sub>	d <sub>2</sub>	a		*	code NO/CS
Pg 7	20	1,270	63	28	9	7,1	11,35	2	113 070
Pg 9	18	1,411	70	28	10	8	13,90	2	113 090
Pg 11	18	1,411	80	32	12,5	10	17,30	2	113 110
Pg 13,5	18	1,411	80	32	16	12,5	19,10	2	113 135
Pg 16	18	1,411	85	32	18	14	21,25	2	113 160
Pg 21	16	1,588	90	36	20	16	26,90	2	113 210
Pg 29	16	1,588	100	36	28	22,4	35,50	2	113 290

\* kusy v sadě / pcs in set / Stck in Satz / штук в наборе

Materiál: NO  
Provedení: nebroušený závit

Material: CS  
Execution: non-ground thread

Werkstoff: WS  
Ausführung: nicht  
geschliffenes Gewinde

Материал: NO  
Изготовлено:  
нешлифованная резьба

BUČOVICE  
TOOLS a.s.

# DIN 352

NO

HSS

## Závitníky sadové Set of hand taps Satzgewindebohrer Метчики наборные

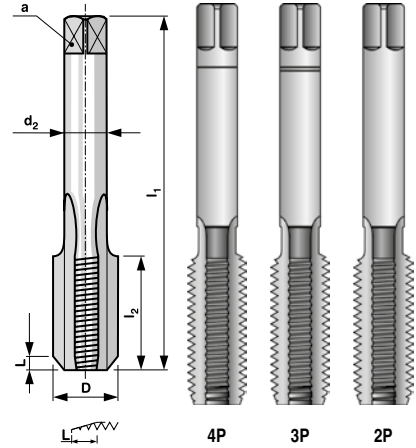
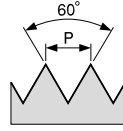
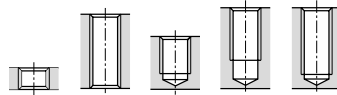

Lícování: 2N / Tolerance: 2N /  
Toleranz: 2N / Подгонка: 2N

M

Metrický závit  
Standard metric thread  
Metrische Regelgewinde  
Метрическая резьба

D	P	l <sub>1</sub>	l <sub>2</sub>	d <sub>2</sub>	a		*	code NO/CS	code HSS
M 1	0,25	32	5,5	2,5	2,1	0,75	3		144 010
M 1,1	0,25	32	5,5	2,5	2,1	0,85	3		144 011
M 1,2	0,25	32	5,5	2,5	2,1	0,95	3		144 012
M 1,4	0,3	32	7	2,5	2,1	1,10	3		144 014
M 1,6	0,35	32	8	2,5	2,1	1,25	3		144 016
M 1,7	0,35	32	8	2,5	2,1	1,35	3		144 017
M 1,8	0,35	32	8	2,5	2,1	1,45	3		144 018
M 2	0,4	36	8	2,8	2,1	1,60	3	114 020	144 020
M 2,2	0,45	36	9	2,8	2,1	1,75	3	114 022	144 022
M 2,5	0,45	40	9	2,8	2,1	2,05	3	114 025	144 025
M 3	0,5	40	11	3,5	2,7	2,50	3	114 030	144 030
M 3,5	0,6	45	13	4	3	2,90	3	114 035	144 035
M 4	0,7	45	13	4,5	3,4	3,30	3	114 040	144 040
M 4,5	0,75	50	16	6	4,9	4,00	3	114 045	144 045
M 5	0,8	50	16	6	4,9	4,20	3	114 050	144 050
M 6	1	50	19	6	4,9	5,00	3	114 060	144 060
M 7	1	50	19	6	4,9	6,00	3	114 070	144 070
M 8	1,25	56	22	6	4,9	6,80	3	114 080	144 080
M 9	1,25	63	22	7	5,5	7,80	3	114 090	144 090
M 10	1,5	70	24	7	5,5	8,50	3	114 100	144 100
M 11	1,5	70	24	8	6,2	9,50	3	114 110	144 110
M 12	1,75	75	29	9	7	10,20	3	114 120	144 120
M 14	2	80	30	11	9	12,00	3	114 140	144 140
M 16	2	80	30	12	9	14,00	3	114 160	144 160
M 18	2,5	95	30	14	11	15,50	3	114 180	144 180
M 20	2,5	95	32	16	12	17,50	3	114 200	144 200
M 22	2,5	100	32	18	14,5	19,50	3	114 220	144 220
M 24	3	110	34	18	14,5	21,00	3	114 240	144 240
M 27	3	110	36	20	16	24,00	3	114 270	144 270
M 30	3,5	125	40	22	18	26,50	3	114 300	144 300
M 33	3,5	125	40	25	20	29,50	3		144 330
M 36	4	150	50	28	22	32,00	3		144 360
M 39	4	150	50	32	24	35,00	3		144 390
M 42	4,5	150	56	32	24	37,50	3		144 420
M 45	4,5	160	58	36	29	40,50	3		144 450
M 48	5	180	65	36	29	43,00	3		144 480
M 52	5	180	65	40	32	37,00	3		144 520
M 56	5,5	180	70	40	32	50,50	3		144 560
M 60	5,5	200	70	45	35	54,50	3		144 600
M 64	6	220	75	50	39	58,00	3		144 640
M 68	6	220	75	50	39	62,00	3		144 680

\* kusy v sadě / pcs in set / Stck in Satz / штук в наборе



**BUČOVICE**  
**TOOLS a.s.**

Materiál: NO; HSS  
Provedení: nebroušený závit  
Závit: pravý

Material: CS; HSS  
Execution: non-ground thread  
Thread: right-hand

Werkstoff: WS; HSS  
Ausführung: nicht  
geschliffenes Gewinde  
Gewinde: rechts

Материал: NO; HSS  
Изготовлено:  
нешлифованная резьба  
Резьба: правая

# DIN 2181

NO

HSS

## Závitníky sadové Set of hand taps Satzgewindebohrer Метчики наборные

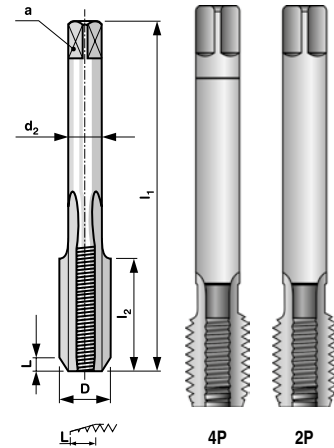
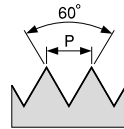
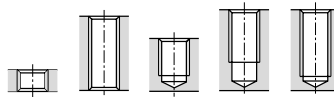

Jemný metrický závit  
Fine metric thread  
Metrische Feingewinde  
Мелкая метрическая резьба

Lícování: 2N / Tolerance: 2N /  
Toleranz: 2N / Подгонка: 2N

MF

4P

2P

D	P	l <sub>1</sub>	l <sub>2</sub>	d <sub>2</sub>	a		*	code NO/CS	code HSS
M 2,5	0,35	40	9	2,8	2,1	2,15	2	114 026	144 026
M 3	0,35	40	9	3,5	2,7	2,65	2	114 031	144 031
M 3,5	0,35	45	10	4,0	3,0	3,15	2	114 036	144 036
M 4	0,5	45	10	4,5	3,4	3,50	2	114 041	144 041
M 4,5	0,5	50	12	6,0	4,9	4,00	2	114 046	144 046
M 5	0,5	50	12	6,0	4,9	4,50	2	114 051	144 051
M 5,5	0,5	50	12	6,0	4,9	5,00	2	114 056	144 056
M 6	0,75	50	14	6,0	4,9	5,20	2	114 061	144 061
M 7	0,75	50	14	6,0	4,9	6,20	2	114 071	144 071
M 8	1	56	22	6,0	4,9	7,00	2	114 081	144 081
M 8	0,75	50	19	6,0	4,9	7,20	2	114 082	144 082
M 9	1	63	22	7,0	5,5	8,00	2	114 091	144 091
M 9	0,75	56	19	7,0	5,5	8,20	2	114 092	144 092
M 10	1,25	70	24	7,0	5,5	8,80	2	114 101	144 101
M 10	1	63	20	7,0	5,5	9,00	2	114 102	144 102
M 10	0,75	63	20	7,0	5,5	9,20	2	114 103	144 103
M 11	1	63	20	8,0	6,2	10,00	2	114 111	144 111
M 11	0,75	63	20	8,0	6,2	10,20	2	114 112	144 112
M 12	1,5	70	22	9,0	7,0	10,50	2	114 121	144 121
M 12	1,25	70	22	9,0	7,0	10,80	2	114 122	144 122
M 12	1	70	22	9,0	7,0	11,00	2	114 123	144 123
M 14	1,5	70	22	11	9,0	12,50	2	114 141	144 141
M 14	1,25	70	22	11	9,0	12,80	2	114 142	144 142
M 14	1	70	22	11	9,0	13,00	2	114 143	144 143
M 15	1	70	22	12	9,0	14,00	2	114 152	144 152
M 16	1,5	70	22	12	9,0	14,50	2	114 161	144 161
M 16	1	70	22	12	9,0	15,00	2	114 162	144 162
M 17	1	70	22	12	9,0	16,00	2	114 171	144 171
M 18	1,5	80	22	14	11,0	16,50	2	114 181	144 181
M 18	1	80	22	14	11,0	17,00	2	114 182	144 182
M 20	1,5	80	22	16	12,0	18,50	2	114 201	144 201
M 20	1	80	22	16	12,0	19,00	2	114 202	144 202
M 22	1,5	80	22	18	14,5	20,50	2	114 221	144 221
M 22	1	80	22	18	14,5	21,00	2	114 222	144 222
M 24	2	90	22	18	14,5	22,00	2	114 241	144 241
M 24	1,5	90	22	18	14,5	22,50	2	114 242	144 242
M 24	1	90	22	18	14,5	23,00	2	114 243	144 243
M 25	1,5	90	22	18	14,5	23,50	2	114 252	144 252
M 26	1,5	90	22	18	14,5	24,50	2	114 262	144 262
M 27	2	90	22	20	16	25,00	2	114 271	144 271
M 27	1,5	90	22	20	16	25,50	2	114 272	144 272
M 27	1	90	22	20	16	26,00	2	114 273	144 273
M 28	2	90	22	20	16	26,00	2	114 281	144 281
M 28	1,5	90	22	20	16	26,50	2	114 282	144 282
M 30	2	90	22	22	18	28,00	2	114 301	144 301
M 30	1,5	90	22	22	18	28,50	2	114 302	144 302
M 30	1	90	22	22	18	29,00	2	114 303	144 303
M 32	1,5	90	22	22	18	30,50	2		144 321
M 33	2	100	25	25	20	31,00	2		144 331
M 33	1,5	100	25	25	20	31,50	2		144 332
M 34	1,5	100	25	28	22	32,50	2		144 341
M 35	1,5	100	25	28	22	33,50	2		144 351
M 36	3	125	36	28	22	33,00	2		144 361
M 36	2	125	30	28	22	34,00	2		144 362
M 36	1,5	100	25	28	22	34,50	2		144 363
M 38	1,5	100	25	28	22	36,50	2		144 381
M 39	3	125	36	32	24	36,00	2		144 391
M 39	2	125	30	32	24	37,00	2		144 392
M 39	1,5	110	25	32	24	37,50	2		144 393
M 40	3	125	36	32	24	37,00	2		144 401

Materiál: NO: HSS  
Provedení: nebroušený závit  
Závit: pravý

Material: CS: HSS  
Execution: non-ground thread  
Thread: right-hand

Werkstoff: WS: HSS  
Ausführung: nicht  
geschliffenes Gewinde  
Gewinde: rechts

Материал: NO: HSS  
Изготовлено:  
нешлифованная резьба  
Резьба: правая

**BUČOVICE  
TOOLS a.s.**



# DIN 2181

NO

HSS

## Závitníky sadové Set of hand taps Satzgewindebohrer Метчики наборные

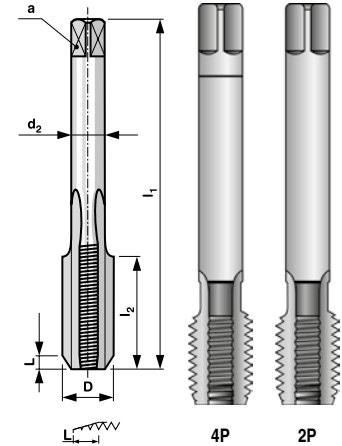
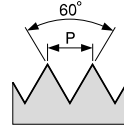
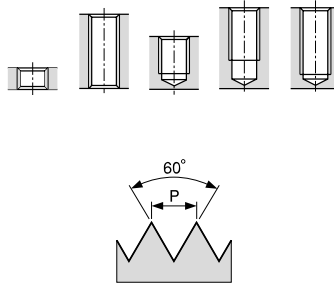

Lícování: 2N / Tolerance: 2N /  
Toleranz: 2N / Подгонка: 2N

MF

Jemný metrický závit  
Fine metric thread  
Metrische Feingewinde  
Мелкая метрическая резьба

4P

2P

D	P	$l_1$	$l_2$	$d_2$	a		*	code NO/CS	code HSS
M 40	2	125	30	32	24	38,00	2		144 402
M 40	1,5	110	25	32	24	38,50	2		144 403
M 42	3	125	36	32	24	39,00	2		144 421
M 42	2	125	30	32	24	40,00	2		144 422
M 42	1,5	110	25	32	24	40,50	2		144 423
M 45	3	125	36	36	29	42,00	2		144 451
M 45	2	125	30	36	29	43,00	2		144 452
M 45	1,5	110	25	36	29	43,50	2		144 453
M 48	3	140	36	36	29	45,00	2		144 481
M 48	2	140	30	36	29	46,00	2		144 482
M 48	1,5	140	25	36	29	46,50	2		144 483
M 50	3	140	36	36	29	47,00	2		144 501
M 50	2	140	30	36	29	48,00	2		144 502
M 50	1,5	140	25	36	29	48,50	2		144 503
M 52	3	140	40	40	32	49,00	2		144 521
M 52	2	140	32	40	32	50,00	2		144 522
M 52	1,5	140	25	40	32	50,50	2		144 523

\* kusy v sadě / pcs in set / Stck in Satz / штук в наборе



**BUČOVICE**  
TOOLS a.s.

Materiál: NO; HSS  
Provedení: nebroušený závit  
Závit: pravý

Material: CS; HSS  
Execution: non-ground thread  
Thread: right-hand

Werkstoff: WS; HSS  
Ausführung: nicht geschliffenes Gewinde  
Gewinde: rechts

Материал: NO; HSS  
Изготовлено: нешлифованная резьба  
Резьба: правая

# DIN 352

NO

HSS

## Závitníky sadové Set of hand taps Satzgewindebohrer Метчики наборные

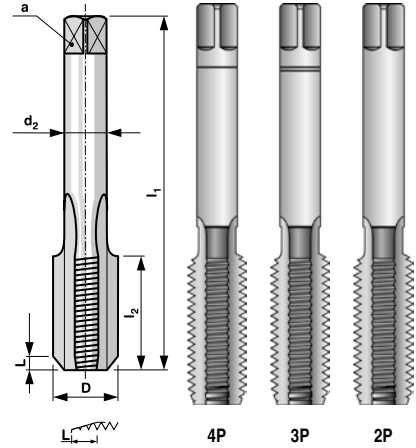
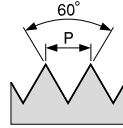
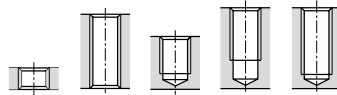

Lícování: 2B / Tolerance: 2B /  
Toleranz: 2B / Подгонка: 2B

UNC

Unifikovaný hrubý závit  
Unified coarse thread  
Unifiziert-Grobgewinde  
Унифицированная чёрная резьба

D	z/1"	P	l <sub>1</sub>	l <sub>2</sub>	d <sub>2</sub>	a		*	code NO/CS	code HSS
UNC 4	40	0,635	40	11	3,5	2,7	2,20	3	125 004	145 004
UNC 5	40	0,635	40	11	3,5	2,7	2,60	3	125 005	145 005
UNC 6	32	0,794	45	12	4	3	2,85	3	125 006	145 006
UNC 8	32	0,794	45	13	4,5	3,4	3,50	3	125 008	145 008
UNC 10	24	1,058	50	16	6	4,9	3,90	3	125 010	145 010
UNC 12	24	1,058	50	16	6	4,9	4,50	3	125 012	145 012
UNC 1/4	20	1,270	50	19	6	4,9	5,20	3	125 140	145 140
UNC 5/16	18	1,411	53	22	6	4,9	6,60	3	125 516	145 516
UNC 3/8	16	1,588	70	24	7	5,5	8,00	3	125 380	145 380
UNC 7/16	14	1,814	70	24	8	6,2	9,40	3	125 716	145 716
UNC 1/2	13	1,954	75	28	9	7	10,75	3	125 120	145 120
UNC 9/16	12	2,117	80	30	11	9	12,25	3	125 916	145 916
UNC 5/8	11	2,309	80	32	12	9	13,50	3	125 580	145 580
UNC 3/4	10	2,540	95	34	14	11	16,50	3	125 340	145 340
UNC 7/8	9	2,822	100	34	18	14,5	19,50	3	125 780	145 780
UNC 1	8	3,175	110	38	18	14,5	22,25	3	125 100	145 100
UNC 1 1/8	7	3,629	125	40	22	18	25,00	3		145 118
UNC 1 1/4	7	3,629	125	40	22	18	28,00	3		145 114
UNC 1 3/8	6	4,233	150	50	28	22	30,70	3		145 138
UNC 1 1/2	6	4,233	150	50	28	22	34,00	3		145 112
UNC 1 3/4	5	5,080	160	58	36	29	39,50	3		145 134
UNC 2	4,5	5,645	180	65	40	32	45,00	3		145 200

\* kusy v sadě / pcs in set / Stck in Satz / штук в наборе

Materiál: NO; HSS  
Provedení: nebroušený závit

Material: CS; HSS  
Execution: non-ground thread

Werkstoff: WS; HSS  
Ausführung: nicht geschliffenes Gewinde

Материал: NO; HSS  
Изготовлено: нешлифованная резьба

**BUČOVICE TOOLS a.s.**

# DIN 2181

NO

HSS

## Závitníky sadové Set of hand taps Satzgewindebohrer Метчики наборные

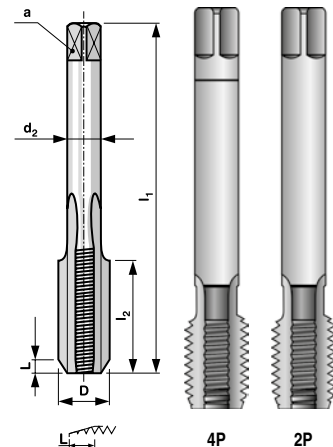
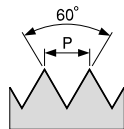
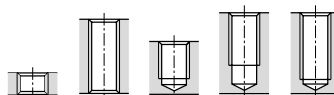

Lícování: 2B / Tolerance: 2B /  
Toleranz: 2B / Подгонка: 2B

UNF

Unifikovaný jemný závit  
Unified fine thread  
Unifiziert-Feingewinde  
Унифицированная мелкая резьба

D	z/1"	P	l <sub>1</sub>	l <sub>2</sub>	d <sub>2</sub>	a		*	code NO/CS	code HSS
UNF 4	48	0,529	40	9	3,5	2,7	2,30	2	126 004	146 004
UNF 5	44	0,577	40	9	3,5	2,7	2,70	2	126 005	146 005
UNF 6	40	0,635	45	10	4	3	3,00	2	126 006	146 006
UNF 8	36	0,706	45	10	4,5	3,4	3,50	2	126 008	146 008
UNF 10	32	0,794	50	12	6	4,9	4,10	2	126 010	146 010
UNF 12	28	0,907	50	12	6	4,9	4,65	2	126 012	146 012
UNF 1/4	28	0,907	50	14	6	4,9	5,50	2	126 140	146 140
UNF 5/16	24	1,058	56	22	6	4,9	6,90	2	126 516	146 516
UNF 3/8	24	1,058	63	20	7	5,5	8,50	2	126 380	146 380
UNF 7/16	20	1,270	63	20	8	6,2	9,90	2	126 716	146 716
UNF 1/2	20	1,270	70	22	9	7	11,50	2	126 120	146 120
UNF 9/16	18	1,411	70	22	11	9	12,90	2	126 916	146 916
UNF 5/8	18	1,411	70	22	12	9	14,50	2	126 580	146 580
UNF 3/4	16	1,588	80	22	14	11	17,50	2	126 340	146 340
UNF 7/8	14	1,814	80	22	18	14,5	20,50	2	126 780	146 780
UNF 1	12	2,117	80	22	18	14,5	23,25	2	126 100	146 100
UNF 1 1/8	12	2,117	90	22	22	18	25,50	2		146 118
UNF 1 1/4	12	2,117	90	22	22	18	29,50	2		146 114
UNF 1 3/8	12	2,117	125	30	28	22	32,50	2		146 138
UNF 1 1/2	12	2,117	125	30	28	22	36,00	2		146 112

\* kusy v sadě / pcs in set / Stck in Satz / штук в наборе



**BUČOVICE**  
TOOLS a.s.

Materiál: NO; HSS  
Provedení: nebroušený závit

Material: CS; HSS  
Execution: non-ground thread

Werkstoff: WS; HSS  
Ausführung: nicht  
geschliffenes Gewinde

Материал: NO; HSS  
Изготовлено:  
шлифованная резьба

### Závitníky sadové Set of hand taps Satzgewindebohrer Метчики наборные

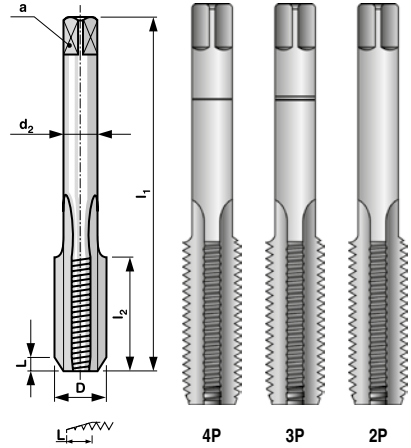
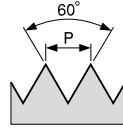
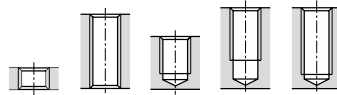

Lícován: 2N / Tolerance: 2N /  
Toleranz: 2N / Подгонка: 2N

M

Metrický závit  
Standard metric thread  
Metrische Regelgewinde  
Метрическая резьба

MF

Jemný metrický závit  
Fine metric thread  
Metrische Feingewinde  
Мелкая метрическая резьба

D	P	l <sub>1</sub>	l <sub>2</sub>	d <sub>2</sub>	a		*	code NO/CS	code HSS
M 2	0,4	41	8	2,5	2	1,60	3	124 020	154 020
M 2,2	0,45	44,5	9,5	2,8	2,24	1,75	3	124 022	154 022
M 2,5	0,45	44,5	9,5	2,8	2,24	2,05	3	124 025	154 025
M 2,5	0,35	44,5	9,5	2,8	2,24	2,15	3	124 026	154 026
M 3	0,5	48	11	3,15	2,5	2,50	3	124 030	154 030
M 3	0,35	48	11	3,15	2,5	2,65	3	124 031	154 031
M 3,5	0,6	50	13	3,55	2,8	2,90	3	124 035	154 035
M 3,5	0,35	50	13	3,55	2,8	3,15	3	124 036	154 036
M 4	0,7	53	13	4	3,15	3,30	3	124 040	154 040
M 4	0,5	53	13	4	3,15	3,50	3	124 041	154 041
M 4,5	0,5	53	13	4,5	3,55	4,00	3	124 045	154 045
M 5	0,8	58	16	5	4	4,20	3	124 050	154 050
M 5	0,5	58	16	5	4	4,50	3	124 051	154 051
M 6	1	66	19	6,3	5	5,00	3	124 060	154 060
M 6	0,75	66	19	6,3	5	5,20	3	124 061	154 061
M 7	1	66	19	7,1	5,6	6,00	3	124 070	154 070
M 7	0,75	66	19	7,1	5,6	6,20	3	124 071	154 071
M 8	1,25	72	22	8	6,3	6,80	3	124 080	154 080
M 8	1	72	22	8	6,3	7,00	3	124 081	154 081
M 9	1,25	72	22	9	7,1	7,80	3	124 090	154 090
M 9	1	72	22	9	7,1	8,00	3	124 091	154 091
M 10	1,5	80	24	10	8	8,50	3	124 100	154 100
M 10	1,25	80	22	10	8	8,80	3	124 101	154 101
M 10	1	80	22	10	8	9,00	3	124 102	154 102
M 11	1,5	85	24	8	6,3	9,50	3	124 111	154 111
M 12	1,75	89	29	9	7,1	10,20	3	124 120	154 120
M 12	1,5	89	24	9	7,1	10,50	3	124 121	154 121
M 12	1,25	89	24	9	7,1	10,80	3	124 122	154 122
M 14	2	95	30	11,2	9	12,00	3	124 140	154 140
M 14	1,5	95	26	11,2	9	12,50	3	124 141	154 141
M 14	1,25	95	26	11,2	9	12,80	3	124 142	154 142
M 15	1,5	95	26	11,2	9	13,50	3	124 151	154 151
M 16	2	102	32	12,5	10	14,00	3	124 160	154 160
M 16	1,5	102	30	12,5	10	14,50	3	124 161	154 161
M 17	1,5	102	30	12,5	10	15,50	3	124 171	154 171
M 18	2,5	112	37	14	11,2	15,50	3	124 180	154 180
M 18	2	112	32	14	11,2	16,00	3	124 181	154 181
M 18	1,5	112	30	14	11,2	16,50	3	124 182	154 182
M 20	2,5	112	37	14	11,2	17,50	3	124 200	154 200
M 20	2	112	35	14	11,2	18,00	3	124 201	154 201
M 20	1,5	112	32	14	11,2	18,50	3	124 202	154 202
M 22	2,5	118	37	16	12,5	19,50	3	124 220	154 220
M 22	2	118	35	16	12,5	20,00	3	124 221	154 221
M 22	1,5	113	32	16	12,5	20,50	3	124 222	154 222
M 24	3	130	45	18	14	21,00	3	124 240	154 240
M 24	2	130	35	18	14	22,00	3	124 241	154 241
M 24	1,5	130	35	18	14	22,50	3	124 242	154 242
M 25	1,5	130	35	18	14	23,50	3	124 252	154 252
M 27	3	135	45	20	16	24,00	3	124 270	154 270
M 27	2	127	37	20	16	25,00	3	124 271	154 271
M 27	1,5	127	37	20	16	25,50	3	124 272	154 272
M 28	2	127	37	20	16	26,00	3	124 280	154 280
M 28	1,5	127	37	20	16	26,50	3	124 281	154 281
M 30	3,5	138	48	20	16	26,50	3	124 300	154 300
M 30	2	127	37	20	16	28,00	3	124 301	154 301
M 30	1,5	127	37	20	16	28,50	3	124 302	154 302

Materiál: NO: HSS  
Provedení: nebroušený závit  
Závit: pravý

Material: CS: HSS  
Execution: non-ground thread  
Thread: right-hand

Werkstoff: WS: HSS  
Ausführung: nicht  
geschliffenes Gewinde  
Gewinde: rechts

Материал: NO: HSS  
Изготовлено:  
нешлифованная резьба  
Резьба: правая

## Závitníky maticové Nut taps Muttergewindebohrer Метчики гаечные

**M**  
Metrický závit  
Standard metric thread  
Metrische Regelgewinde  
Метрическая резьба

**MF**  
Jemný metrický závit  
Fine metric thread  
Metrische Feingewinde  
Мелкая метрическая резьба

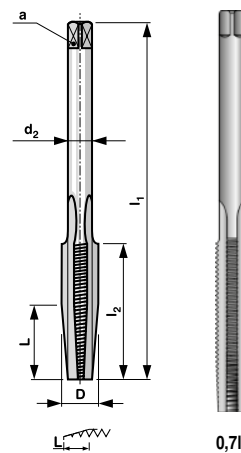
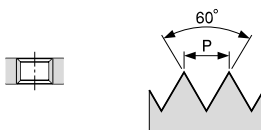

Lícování: 2N / Tolerance: 2N /  
Toleranz: 2N / Подгонка: 2N

D	P	l <sub>1</sub>	l <sub>2</sub>	d <sub>2</sub>		a	code NO/CS
M 5	0,8	70	28	3,55	4,20	2,8	117 050
M 5,5	0,5	63	24	4,0	5,00	3,15	117 055
M 6	1	80	32	4,7	5,00	3,55	117 060
M 7	1	80	32	5,6	6,00	4,5	117 070
M 8	1,25	90	38	6,3	6,80	5	117 080
M 8	1	80	32	6,3	7,00	5	117 081
M 9	1,25	100	38	7,1	7,80	5,6	117 090
M 10	1,5	110	45	7,1	8,50	5,6	117 100
M 10	0,75	90	30	7,1	9,20	5,6	117 103
M 12	1,75	125	50	9	10,20	7,1	117 120
M 14	2	140	60	11,2	12,00	9	117 140
M 16	2	140	60	12,5	14,00	10	117 160
M 18	2,5	160	70	14	15,50	11,2	117 180
M 20	2,5	160	70	14	17,50	11,2	117 200
M 22	2,5	180	70	16	19,50	12,5	117 220
M 24	3	180	85	18	21,00	14	117 240



**BUČOVICE  
TOOLS a.s.**

Materiál: NO  
Provedení: nebroušený závit  
Závit: pravý

Material: CS  
Execution: non-ground thread  
Thread: right-hand

Werkstoff: WS  
Ausführung: nicht  
geschliffenes Gewinde  
Gewinde: rechts

Материал: NO  
Изготовлено:  
нешлифованная резьба  
Резьба: правая

# PN 8/3070

NO

HSS

## Závitníky maticové Nut taps Muttergewindebohrer Метчики гаечные

M

Metrický závit  
Standard metric thread  
Metrische Regelgewinde  
Метрическая резьба

MF

Jemný metrický závit  
Fine metric thread  
Metrische Feingewinde  
Мелкая метрическая резьба

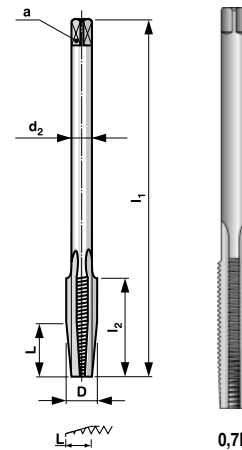
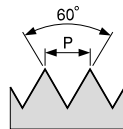

Lícování: 2N / Tolerance: 2N /  
Toleranz: 2N / Подгонка: 2N

0,7l<sub>2</sub>

D	P	l <sub>1</sub>	l <sub>2</sub>	d <sub>2</sub>		a	code NO/CS	code NO/CS LH	code HSS
M 3	0,5	48	13	2,24	2,50	-	118 030	128 030	148 030
M 3,5	0,6	52	15	2,5	2,90	-	118 035	128 035	148 035
M 4	0,7	58	18	2,8	3,30	-	118 040	128 040	148 040
M 5	0,8	70	20	3,55	4,20	2,8	118 050	128 050	148 050
M 6	1	80	25	4,7	5,00	3,55	118 060	128 060	148 060
M 7	1	80	25	5,6	6,00	4,5	118 070	128 070	148 070
M 7	0,75	70	20	5,6	6,20	4,5	118 071		148 071
M 8	1,25	90	30	6,3	6,80	5	118 080	128 080	148 080
M 8	1	80	25	6,3	7,00	5	118 081		148 081
M 10	1,5	110	35	7,1	8,50	5,6	118 100	128 100	148 100
M 10	1,25	90	30	7,1	8,80	5,6	118 101		148 101
M 10	1	90	25	7,1	9,00	5,6	118 102		148 102
M 12	1,75	125	43	9	10,20	7,1	118 120	128 120	148 120
M 12	1,5	110	35	9	10,50	7,1	118 121		148 121
M 12	1,25	110	30	9	10,80	7,1	118 122		148 122
M 12	1	110	25	9	11,00	7,1	118 123		148 123
M 14	2	140	50	11,2	12,00	9	118 140		148 140
M 14	1,5	110	35	11,2	12,50	9	118 141		148 141
M 16	2	140	50	12,5	14,00	10	118 160		148 160
M 16	1,5	125	35	12,5	14,50	10	118 161		148 161
M 18	2,5	160	60	14	15,50	11,5	118 180		148 180
M 18	1,5	125	35	14	16,50	11,2	118 181		148 181
M 20	2,5	160	60	14	17,50	11,2	118 200		148 200
M 20	1,5	140	35	14	18,50	11,2	118 201		148 201

Materiál: NO; HSS  
Provedení: nebroušený závit  
Závit: pravý, levý - dle požadavku

Material: CS; HSS  
Execution: non-ground thread  
Thread: right-hand, left-hand - on request

Werkstoff: WS; HSS  
Ausführung: nicht geschliffenes Gewinde  
Gewinde: rechts, links - nach dem Anspruch

Материал: NO; HSS  
Изготовлено: нешлифованная резьба  
Резьба: правая, левая - по заказу



**ČSN 22 3074****NO****HSS**

**Závitníky maticové**  
**Nut taps**  
**Muttergewindebohrer**  
**Метчики гаечные**

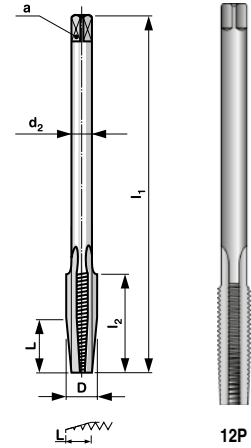
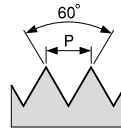

12P

**M**

Metrický závit  
 Standard metric thread  
 Metrische Regelgewinde  
 Метрическая резьба

**MF**

Jemný metrický závit  
 Fine metric thread  
 Metrische Feingewinde  
 Мелкая метрическая резьба

Lícování: 2N / Tolerance: 2N /  
 Toleranz: 2N / Подгонка: 2N

D	P	l <sub>1</sub>	l <sub>2</sub>	d <sub>2</sub>		a	code NO/CS	code HSS
M 2	0,4	60	8	1,4	1,60	-	119 020	149 020
M 2,2	0,45	60	9	1,6	1,75	-	119 022	149 022
M 2,5	0,45	60	9	1,8	2,05	-	119 025	149 025
M 2,5	0,35	60	7	1,8	2,15	-	119 026	149 026
M 3	0,5	70	10	2,24	2,50	-	119 030	149 030
M 3	0,35	70	7	2,24	2,65	-	119 031	149 031
M 3,5	0,6	80	12	2,5	2,90	-	119 035	149 035
M 3,5	0,35	80	7	2,5	3,15	-	119 036	149 036
M 4	0,7	90	14	2,8	3,30	-	119 040	149 040
M 4	0,5	90	10	2,8	3,50	-	119 041	149 041
M 4,5	0,5	100	10	3,15	4,00	-	119 045	149 045
M 5	0,8	110	16	3,55	4,20	2,8	119 050	149 050
M 5	0,5	110	10	3,55	4,50	2,8	119 051	149 051
M 5,5	0,5	110	10	4,5	5,00	3,55	119 055	149 055
M 6	1	120	20	4,5	5,00	3,55	119 060	149 060
M 6	0,75	120	16	4,5	5,50	3,55	119 061	149 061
M 7	1	120	20	5,6	6,00	4,5	119 070	149 070
M 7	0,75	120	16	5,6	6,20	4,5	119 071	149 071
M 8	1,25	140	25	6,3	6,80	5	119 080	149 080
M 8	1	140	20	6,3	7,00	5	119 081	149 081
M 8	0,75	140	16	6,3	7,20	5	119 082	149 082
M 9	1	140	20	7,1	8,00	5,6	119 090	149 090
M 10	1,5	160	30	8	8,50	6,3	119 100	149 100
M 10	1,25	160	25	8	8,80	6,3	119 101	149 101
M 10	1	160	20	8	9,00	6,3	119 102	149 102
M 12	1,75	180	36	9	10,20	7,1	119 120	149 120
M 12	1,5	180	30	9	10,80	7,1	119 121	149 121
M 12	1,25	180	25	9	11,00	7,1	119 122	149 122
M 14	2	180	40	10	12,00	8	119 140	149 140
M 14	1,5	180	30	10	12,50	8	119 141	149 141
M 14	1,25	180	25	10	12,80	8	119 142	149 142
M 16	2	200	40	12,5	14,00	10	119 160	149 160
M 16	1,5	200	30	12,5	14,50	10	119 161	149 161
M 18	2,5	200	50	14	15,50	11,2	119 180	149 180
M 18	1,5	200	30	14	16,50	11,2	119 181	149 181
M 20	2,5	220	50	16	17,50	12,5	119 200	149 200
M 20	1,5	220	30	16	18,50	12,5	119 201	149 201
M 22	2,5	220	50	18	19,50	14	119 220	149 220
M 22	1,5	220	30	18	20,50	14	119 221	149 221
M 24	3	250	60	18	21,00	14	119 240	149 240
M 24	2	250	40	18	22,00	14	119 241	149 241
M 24	1,5	250	30	18	22,50	14	119 242	149 242



**BUČOVICE**  
**TOOLS a.s.**

Materiál: NO; HSS  
 Provedení: nebroušený závit  
 Závit: pravý

Material: CS; HSS  
 Execution: non-ground thread  
 Thread: right-hand

Werkstoff: WS; HSS  
 Ausführung: nicht  
 geschliffenes Gewinde  
 Gewinde: rechts

Материал: NO; HSS  
 Изготовлено:  
 нешлифованная резьба  
 Резьба: правая

**ČSN 22 3064****NO**

**Závitníky maticové**  
**Nut taps**  
**Muttergewindebohrer**  
**Метчики гаечные**

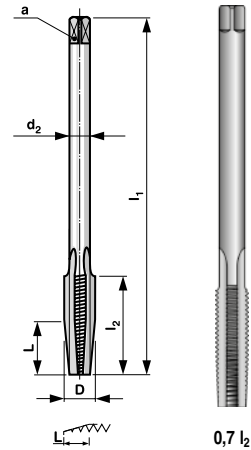
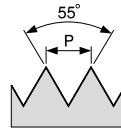

**G** Trubkový závit  
 Pipe thread  
 Rohrgewinde  
 Трубная резьба

Lícování: A / Tolerance: A /  
 Toleranz: A / Подгонка: A

0,7 l<sub>2</sub>

D	z/1"	P	l <sub>1</sub>	l <sub>2</sub>	d <sub>2</sub>	a		code NO/CS
G 1/16"	28	0,907	140	20	5,6	6	4,50	139 116
G 1/8"	28	0,907	140	20	8	6,3	6,30	139 180
G 1/4"	19	1,337	180	30	10	8	8,00	139 140
G 3/8"	19	1,337	200	30	12,5	10	10,00	139 380
G 1/2"	14	1,814	220	40	14	12,5	12,50	139 120
G 5/8"	14	1,814	220	40	18	14	14,00	139 580
G 3/4"	14	1,814	250	40	20	16	24,50	139 340
G 1"	11	2,309	280	60	25	20	30,75	139 100

Materiál: NO  
 Provedení: nebroušený závit  
 Závit: pravý

Material: CS  
 Execution: non-ground thread  
 Thread: right-hand

Werkstoff: WS  
 Ausführung: nicht  
 geschliffenes Gewinde  
 Gewinde: rechts

Material: NO  
 Изготовлено:  
 нешлифованная резьба  
 Резьба: правая

**PN 8/3016****HSS**

**Závitové bity**  
**Screwdriver-bits**  
**Gewindebohrer-Bits**  
**Метчики с шестигран-**  
**ным держак**

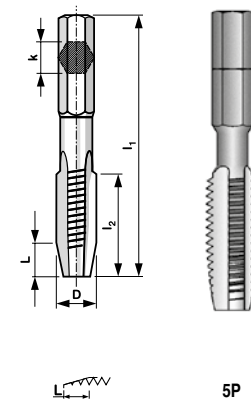
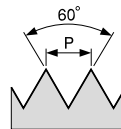

**M** Metrický závit  
 Standard metric thread  
 Metrische Regelgewinde  
 Метрическая резьба

Lícování: 2N / Tolerance: 2N /  
 Toleranz: 2N / Подгонка: 2N

5P

D	P	l <sub>1</sub>	l <sub>2</sub>		k	code HSS
M 3	0,5	40	13	2,50	1/4"	940 030
M 4	0,7	40	12	3,30	1/4"	940 040
M 5	0,8	40	11,5	4,20	1/4"	940 050
M 6	1	40	11	5,00	1/4"	940 060
M 8	1,25	40	17	6,80	1/4"	940 080
M 10	1,5	40	15	8,50	1/4"	940 100
M 12	1,75	40	15	10,20	1/4"	940 120

Materiál: HSS  
 Provedení: nebroušený závit  
 Závit: pravý

Material: HSS  
 Execution: non-ground thread  
 Thread: right-hand

Werkstoff: HSS  
 Ausführung: nicht  
 geschliffenes Gewinde  
 Gewinde: rechts

Material: HSS  
 Изготовлено:  
 нешлифованная резьба  
 Резьба: правая

**BUČOVICE**  
**TOOLS a.s.**

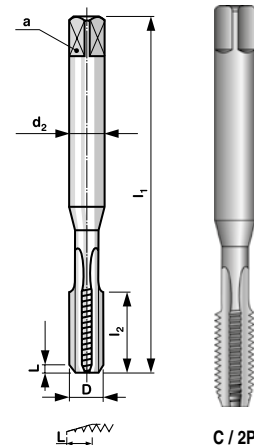
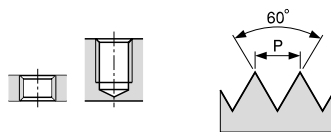

**DIN 371****HSS****HSSE****Strojní závitníky** - válcované s přímou drážkou**Machine taps** - rolled with straight flute**Maschinen-Gewindebohrer** - gewalzt mit gerade Nuten**Механические метчики** - катанные с прямой канавкой

C / 2P

M  
Metrický závit  
Standard metric thread  
Metrische Regelgewinde  
Метрическая резьба

Lícování: 2N / Tolerance: 2N /  
Toleranz: 2N / Подгонка: 2N

D	P	l <sub>1</sub>	l <sub>2</sub>	d <sub>2</sub>	a		code HSS	code HSSE
M 2	0,4	45	8	2,8	2,1	1,60	101 020	191 020
M 3	0,5	56	11	3,5	2,7	2,50	101 030	191 030
M 4	0,7	63	13	4,5	3,4	3,30	101 040	191 040
M 5	0,8	70	16	6,0	4,9	4,20	101 050	191 050
M 6	1	80	19	6,0	4,9	5,00	101 060	191 060
M 8	1,25	90	22	8,0	6,2	6,80	101 080	191 080
M 10	1,5	100	24	10,0	8,0	8,50	101 100	191 100

Materiál: HSS; HSSE  
Provedení: nebroušený závit  
Závit: pravý

Material: HSS; HSSE  
Execution: non-ground thread  
Thread: right-hand

Werkstoff: HSS; HSSE  
Ausführung: nicht geschliffenes Gewinde  
Gewinde: rechts

Материал: HSS; HSSE  
Изготовлено: нешлифованная резьба  
Резьба: правая

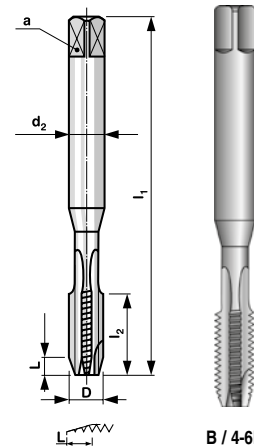
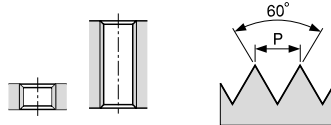
**DIN 371****HSS****HSSE****Strojní závitníky** - válcované přímá drážka s lamačem třísek**Machine taps** - rolled with spiral point**Maschinen-Gewindebohrer** - gewalzt mit Schälanschnitt**Механические метчики** - катанные с ломателем стружек

B / 4-6P

M  
Metrický závit  
Standard metric thread  
Metrische Regelgewinde  
Метрическая резьба

Lícování: 2N / Tolerance: 2N /  
Toleranz: 2N / Подгонка: 2N

D	P	l <sub>1</sub>	l <sub>2</sub>	d <sub>2</sub>	a		code HSS	code HSSE
M 3	0,5	56	11	3,5	2,7	2,50	102 030	192 030
M 4	0,7	63	13	4,5	3,4	3,30	102 040	192 040
M 5	0,8	70	16	6,0	4,9	4,20	102 050	192 050
M 6	1	80	19	6,0	4,9	5,00	102 060	192 060
M 8	1,25	90	22	8,0	6,2	6,80	102 080	192 080
M 10	1,5	100	24	10,0	8,0	8,50	102 100	192 100



**BUČOVICE**  
**TOOLS a.s.**

Materiál: HSS; HSSE  
Provedení: nebroušený závit  
Závit: pravý

Material: HSS; HSSE  
Execution: non-ground thread  
Thread: right-hand

Werkstoff: HSS; HSSE  
Ausführung: nicht geschliffenes Gewinde  
Gewinde: rechts

Материал: HSS; HSSE  
Изготовлено: нешлифованная резьба  
Резьба: правая

**DIN 371**

**HSS**

**HSSE**

**Strojní závitníky** - válcované  
se šroubovitými drážkami 35°

**Machine taps** - rolled  
with spiral flute 35°

**Maschinen-Gewinde-  
bohrer** - gewalzt mit Rechtsspiralnute 35°

**Механические метчики**  
- катанные с винтовыми дорожками 35°

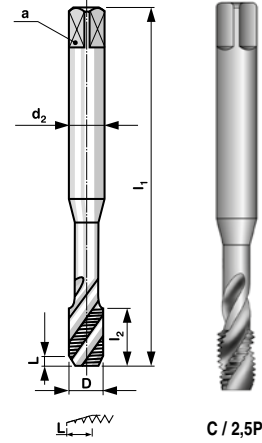
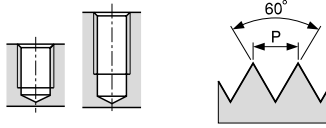

Lícování: 2N / Tolerance: 2N /  
Toleranz: 2N / Подгонка: 2N

**M** Metrický závit  
Standard metric thread  
Metrische Regelgewinde  
Метрическая резьба

D	P	l <sub>1</sub>	l <sub>2</sub>	d <sub>2</sub>	a		code HSS	code HSSE
M 3	0,5	56	5	3,5	2,7	2,50	103 030	193 030
M 4	0,7	63	7	4,5	3,4	3,30	103 040	193 040
M 5	0,8	70	8	6,0	4,9	4,20	103 050	193 050
M 6	1	80	10	6,0	4,9	5,00	103 060	193 060
M 8	1,25	90	13	8,0	6,2	6,80	103 080	193 080
M 10	1,5	100	15	10,0	8,0	8,50	103 100	193 100

Materiál: HSS; HSSE  
Provedení: nebroušený závit  
Závit: pravý

Material: HSS; HSSE  
Execution: non-ground thread  
Thread: right-hand

Werkstoff: HSS; HSSE  
Ausführung: nicht  
geschliffenes Gewinde  
Gewinde: rechts

Материал: HSS; HSSE  
Изготовлено:  
нешлифованная резьба  
Резьба: правая

**BUČOVICE  
TOOLS a.s.**

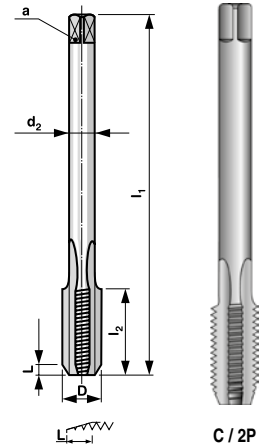
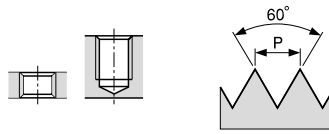
**DIN 374****HSS****Strojní závitníky** - válcované  
s přímou drážkou**Machine taps** - rolled  
with straight flute**Maschinen-Gewinde-  
bohrer** - gewalzt mit gerade Nuten**Механические метчики**  
- катанные с прямой канавкой

**Jemný metrický závit**  
Fine metric thread  
Metrische Feingewinde  
Мелкая метрическая резьба

Lícování: 2N / Tolerance: 2N /  
Toleranz: 2N / Подгонка: 2N

**MF****C / 2P**

D	P	l <sub>1</sub>	l <sub>2</sub>	d <sub>2</sub>	a		code HSS
M 3	0,35	56	8	2,2	-	2,65	107 031
M 4	0,5	63	10	2,8	2,1	3,50	107 041
M 5	0,5	70	12	3,5	2,7	4,50	107 051
M 6	0,75	80	14	4,5	3,4	5,20	107 061
M 6	0,5	80	14	4,5	3,4	5,50	107 062
M 8	1	90	22	6,0	4,9	7,00	107 081
M 8	0,75	80	18	6,0	4,9	7,20	107 082
M 10	1,25	100	24	7,0	5,5	8,30	107 101
M 10	1	90	20	7,0	5,5	9,00	107 102
M 10	0,75	90	20	7,0	5,5	9,20	107 103
M 12	1,5	100	22	9,0	7,0	10,50	107 121
M 12	1,25	100	22	9,0	7,0	10,30	107 122
M 12	1	100	22	9,0	7,0	11,00	107 123
M 14	1,5	100	22	11,0	9,0	12,50	107 141
M 14	1,25	100	22	11,0	9,0	12,80	107 142
M 14	1	100	22	11,0	9,0	13,00	107 143
M 16	1,5	100	22	12,0	9,0	14,50	107 161
M 16	1	100	22	12,0	9,0	15,00	107 162
M 18	1,5	110	25	14,0	11,0	16,50	107 181
M 18	1	110	25	14,0	11,0	17,00	107 182
M 20	1,5	125	25	16,0	12,0	18,50	107 201
M 20	1	125	25	16,0	12,0	19,00	107 202
M 22	1,5	125	25	18,0	14,5	20,50	107 221
M 22	1	125	25	18,0	14,5	21,00	107 222
M 24	2	140	28	18,0	14,5	22,00	107 241
M 24	1,5	140	28	18,0	14,5	22,50	107 242
M 24	1	140	28	18,0	14,5	23,00	107 243
M 25	1,5	140	28	18,0	14,5	23,50	107 251
M 26	1,5	140	28	18,0	14,5	24,50	107 261
M 27	2	140	28	20,0	16,0	25,00	107 271
M 27	1,5	140	28	20,0	16,0	25,50	107 272
M 27	1	140	28	20,0	16,0	26,00	107 273
M 28	1,5	140	28	20,0	16,0	26,50	107 281
M 30	2	150	28	22,0	18,0	28,00	107 301
M 30	1,5	150	28	22,0	18,0	28,50	107 302
M 30	1	150	28	22,0	18,0	29,00	107 303

**BUČOVICE  
TOOLS a.s.**

Materiál: HSS  
Provedení: nebroušený závit  
Závit: pravý

Material: HSS  
Execution: non-ground thread  
Thread: right-hand

Werkstoff: HSS  
Ausführung: nicht  
geschliffenes Gewinde  
Gewinde: rechts

Материал: HSS  
Изготовлено:  
нешлифованная резьба  
Резьба: правая

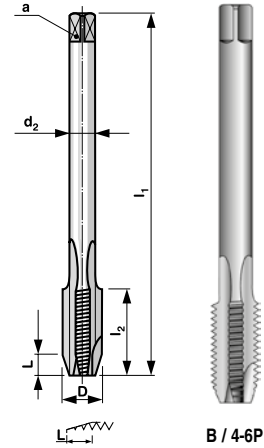
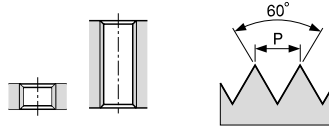
**DIN 374****HSS****Strojní závitníky** - válcované  
přímá drážka s lamačem třísek**Machine taps** - rolled  
with spiral point**Maschinen-Gewinde-  
bohrer** - gewalzt mit Schälanschnitt**Механические метчики**  
- катанные с ломателем стружек

B / 4-6P

**MF**Jemný metrický závit  
Fine metric thread  
Metrische Feingewinde  
Мелкая метрическая резьбаLícování: 2N / Tolerance: 2N /  
Toleranz: 2N / Подгонка: 2N

D	P	l <sub>1</sub>	l <sub>2</sub>	d <sub>2</sub>	a		code HSS
M 3	0,35	56	8	2,2	-	2,65	108 031
M 4	0,5	63	10	2,8	2,1	3,50	108 041
M 5	0,5	70	12	3,5	2,7	4,50	108 051
M 6	0,75	80	14	4,5	3,4	5,20	108 061
M 6	0,5	80	14	4,5	3,4	5,50	108 062
M 8	1	90	22	6,0	4,9	7,00	108 081
M 8	0,75	80	18	6,0	4,9	7,20	108 082
M 10	1,25	100	24	7,0	5,5	8,30	108 101
M 10	1	90	20	7,0	5,5	9,00	108 102
M 10	0,75	90	20	7,0	5,5	9,20	108 103
M 12	1,5	100	22	9,0	7,0	10,50	108 121
M 12	1,25	100	22	9,0	7,0	10,30	108 122
M 12	1	100	22	9,0	7,0	11,00	108 123
M 14	1,5	100	22	11,0	9,0	12,50	108 141
M 14	1,25	100	22	11,0	9,0	12,80	108 142
M 14	1	100	22	11,0	9,0	13,00	108 143
M 16	1,5	100	22	12,0	9,0	14,50	108 161
M 16	1	100	22	12,0	9,0	15,00	108 162
M 18	1,5	110	25	14,0	11,0	16,50	108 181
M 18	1	110	25	14,0	11,0	17,00	108 182
M 20	1,5	125	25	16,0	12,0	18,50	108 201
M 20	1	125	25	16,0	12,0	19,00	108 202

Materiál: HSS  
Provedení: nebroušený závit  
Závit: pravýMaterial: HSS  
Execution: non-ground thread  
Thread: right-handWerkstoff: HSS  
Ausführung: nicht  
geschliffenes Gewinde  
Gewinde: rechtsМатериал: HSS  
Изготовлено:  
нешлифованная резьба  
Резьба: правая

**BUČOVICE  
TOOLS a.s.**

**DIN 374****HSS**

**Strojní závitníky** - válcované  
se šroubovitými drážkami 35°

**Machine taps** - rolled  
with spiral flute 35°

**Maschinen-Gewinde-  
bohrer** - gewalzt mit Rechtsspiralnute 35°

**Механические метчики**  
- катанные с винтовыми дорожками 35°

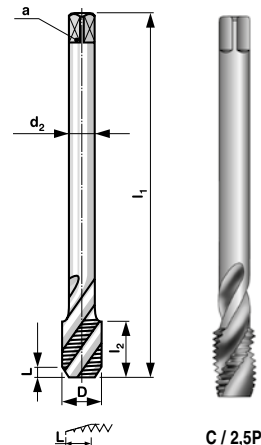
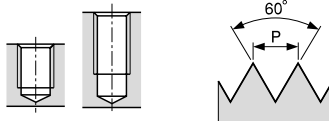

Jemný metrický závit  
Fine metric thread  
Metrische Feingewinde  
Мелкая метрическая резьба

Lícování: 2N / Tolerance: 2N /  
Toleranz: 2N / Подгонка: 2N

**MF****C / 2,5P**

D	P	l <sub>1</sub>	l <sub>2</sub>	d <sub>2</sub>	a		code HSS
M 3	0,35	56	8	2,2	-	2,65	109 031
M 4	0,5	63	10	2,8	2,1	3,50	109 041
M 5	0,5	70	12	3,5	2,7	4,50	109 051
M 6	0,75	80	14	4,5	3,4	5,20	109 061
M 6	0,5	80	14	4,5	3,4	5,50	109 062
M 8	1	90	22	6,0	4,9	7,00	109 081
M 8	0,75	80	18	6,0	4,9	7,20	109 082
M 10	1,25	100	24	7,0	5,5	8,30	109 101
M 10	1	90	20	7,0	5,5	9,00	109 102
M 10	0,75	90	20	7,0	5,5	9,20	109 103
M 12	1,5	100	22	9,0	7,0	10,50	109 121
M 12	1,25	100	22	9,0	7,0	10,30	109 122
M 12	1	100	22	9,0	7,0	11,00	109 123
M 14	1,5	100	22	11,0	9,0	12,50	109 141
M 14	1,25	100	22	11,0	9,0	12,80	109 142
M 14	1	100	22	11,0	9,0	13,00	109 143
M 16	1,5	100	22	12,0	9,0	14,50	109 161
M 16	1	100	22	12,0	9,0	15,00	109 162
M 18	1,5	110	25	14,0	11,0	16,50	109 181
M 18	1	110	25	14,0	11,0	17,00	109 182
M 20	1,5	125	25	16,0	12,0	18,50	109 201
M 20	1	125	25	16,0	12,0	19,00	109 202
M 22	1,5	125	25	18,0	14,5	20,50	109 221
M 22	1	125	25	18,0	14,5	21,00	109 222
M 24	2	140	28	18,0	14,5	22,00	109 241
M 24	1,5	140	28	18,0	14,5	22,50	109 242
M 24	1	140	28	18,0	14,5	23,00	109 243
M 25	1,5	140	28	18,0	14,5	23,50	109 251
M 26	1,5	140	28	18,0	14,5	24,50	109 261
M 27	2	140	28	20,0	16,0	25,00	109 271
M 27	1,5	140	28	20,0	16,0	25,50	109 272
M 27	1	140	28	20,0	16,0	26,00	109 273
M 28	1,5	140	28	20,0	16,0	26,50	109 281
M 30	2	150	28	22,0	18,0	28,00	109 301
M 30	1,5	150	28	22,0	18,0	28,50	109 302
M 30	1	150	28	22,0	18,0	29,00	109 303



**BUČOVICE  
TOOLS a.s.**

Materiál: HSS  
Provedení: nebroušený závit  
Závit: pravý

Material: HSS  
Execution: non-ground thread  
Thread: right-hand

Werkstoff: HSS  
Ausführung: nicht  
geschliffenes Gewinde  
Gewinde: rechts

Материал: HSS  
Изготовлено:  
нешлифованная резьба  
Резьба: правая

# DIN 376

## HSS

## HSSE

**Strojní závitníky** - válcované  
s přímou drážkou

**Machine taps** - rolled  
with straight flute

**Maschinen-Gewinde-  
bohrer** - gewalzt mit gerade Nuten

**Механические метчики**  
- катанные с прямой канавкой

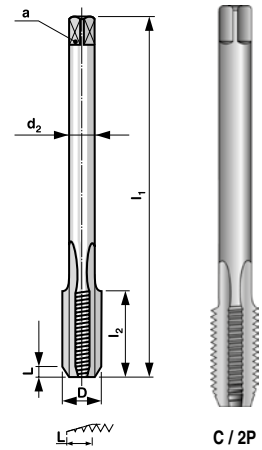
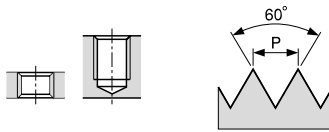

**M** Metrický závit  
Standard metric thread  
Metrische Regelgewinde  
Метрическая резьба

Lícování: 2N / Tolerance: 2N /  
Toleranz: 2N / Подгонка: 2N

C / 2P

D	P	l <sub>1</sub>	l <sub>2</sub>	d <sub>2</sub>	a		code HSS	code HSSE
M 3	0,5	56	11	2,2	-	2,50	104 030	194 030
M 4	0,7	63	13	2,8	2,1	3,30	104 040	194 040
M 5	0,8	70	16	3,5	2,7	4,20	104 050	194 050
M 6	1	80	19	4,5	3,4	5,00	104 060	194 060
M 8	1,25	90	22	6,0	4,9	6,80	104 080	194 080
M 10	1,5	100	24	7,0	5,5	8,50	104 100	194 100
M 12	1,75	110	28	9,0	7,0	10,20	104 120	194 120
M 14	2	110	30	11,0	9,0	12,00	104 140	194 140
M 16	2	110	32	12,0	9,0	14,00	104 160	194 160
M 18	2,5	125	34	14,0	11,0	15,50	104 180	194 180
M 20	2,5	140	34	16,0	12,0	17,50	104 200	194 200
M 22	2,5	140	34	18,0	14,5	19,50	104 220	194 220
M 24	3	160	38	18,0	14,5	21,00	104 240	194 240
M 27	3	160	38	20,0	16,0	24,00	104 270	194 270
M 30	3,5	180	45	22,0	18,0	26,50	104 300	194 300

# DIN 376

## HSS

## HSSE

**Strojní závitníky** - válcované  
přímá drážka s lamačem třísek

**Machine taps** - rolled  
with spiral point

**Maschinen-Gewinde-  
bohrer** - gewalzt mit Schälanschnitt

**Механические метчики**  
- катанные с ломателем стружек

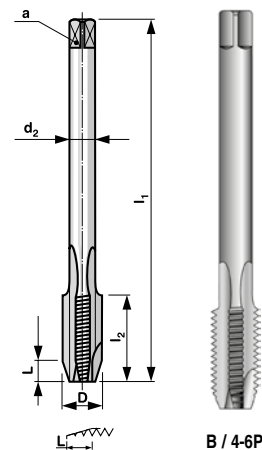
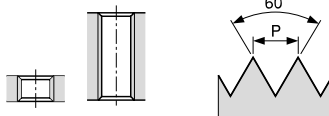

**M** Metrický závit  
Standard metric thread  
Metrische Regelgewinde  
Метрическая резьба

Lícování: 2N / Tolerance: 2N /  
Toleranz: 2N / Подгонка: 2N

B / 4-6P

D	P	l <sub>1</sub>	l <sub>2</sub>	d <sub>2</sub>	a		code HSS	code HSSE
M 3	0,5	56	11	2,2	-	2,50	105 030	195 030
M 4	0,7	63	13	2,8	2,1	3,30	105 040	195 040
M 5	0,8	70	16	3,5	2,7	4,20	105 050	195 050
M 6	1	80	19	4,5	3,4	5,00	105 060	195 060
M 8	1,25	90	22	6,0	4,9	6,80	105 080	195 080
M 10	1,5	100	24	7,0	5,5	8,50	105 100	195 100
M 12	1,75	110	28	9,0	7,0	10,20	105 120	195 120
M 14	2	110	30	11,0	9,0	12,00	105 140	195 140
M 16	2	110	32	12,0	9,0	14,00	105 160	195 160
M 18	2,5	125	34	14,0	11,0	15,50	105 180	195 180
M 20	2,5	140	34	16,0	12,0	17,50	105 200	195 200

Materiál: HSS; HSSE  
Provedení: nebroušený závit  
Závit: pravý

Material: HSS; HSSE  
Execution: non-ground thread  
Thread: right-hand

Werkstoff: HSS; HSSE  
Ausführung: nicht  
geschliffenes Gewinde  
Gewinde: rechts

Материал: HSS; HSSE  
Изготовлено:  
нешлифованная резьба  
Резьба: правая

**BUČOVICE  
TOOLS a.s.**

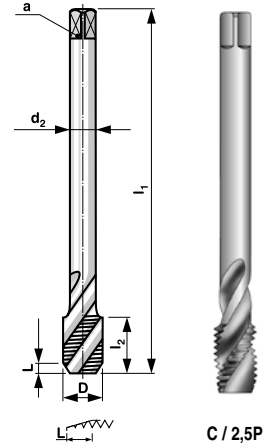
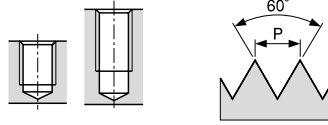
**DIN 376****HSS****HSSE****Strojní závitníky** - válcované  
se šroubovitými drážkami 35°**Machine taps** - rolled  
with spiral flute 35°**Maschinen-Gewinde-  
bohrer** - gewalzt mit Rechtsspiralnute 35°**Механические метчики**  
- катанные с винтовыми дорожками 35°

**M** Metrický závit  
Standard metric thread  
Metrische Regelgewinde  
Метрическая резьба

Lícování: 2N / Tolerance: 2N /  
Toleranz: 2N / Подгонка: 2N

C / 2,5P

D	P	l <sub>1</sub>	l <sub>2</sub>	d <sub>2</sub>	a		code HSS	code HSSE
M 3	0,5	56	5	2,2	-	2,50	106 030	196 030
M 4	0,7	63	7	2,8	2,1	3,30	106 040	196 040
M 5	0,8	70	8	3,5	2,7	4,20	106 050	196 050
M 6	1	80	10	4,5	3,4	5,00	106 060	196 060
M 8	1,25	90	13	6,0	4,9	6,80	106 080	196 080
M 10	1,5	100	15	7,0	5,5	8,50	106 100	196 100
M 12	1,75	110	18	9,0	7,0	10,20	106 120	196 120
M 14	2	110	20	11,0	9,0	12,00	106 140	196 140
M 16	2	110	20	12,0	9,0	14,00	106 160	196 160
M 18	2,5	125	25	14,0	11,0	15,50	106 180	196 180
M 20	2,5	140	25	16,0	12,0	17,50	106 200	196 200
M 22	2,5	140	25	18,0	14,5	19,50	106 220	196 220
M 24	3	160	30	18,0	14,5	21,00	106 240	196 240
M 27	3	160	30	20,0	16,0	24,00	106 270	196 270
M 30	3,5	180	35	22,0	18,0	26,50	106 300	196 300

**BUČOVICE  
TOOLS a.s.**

Materiál: HSS; HSSE  
Provedení: nebroušený závit  
Závit: pravý

Material: HSS; HSSE  
Execution: non-ground thread  
Thread: right-hand

Werkstoff: HSS; HSSE  
Ausführung: nicht  
geschliffenes Gewinde  
Gewinde: rechts

Материал: HSS; HSSE  
Изготовлено:  
нешлифованная резьба  
Резьба: правая

# ČSN 22 3042

## HSSE

**Strojní závitníky** - broušený s přímou drážkou

**Machine taps** - grounded with straight flute

**Maschinen-Gewindebohrer** - geschliffen mit gerade Nuten

**Механические метчики** - шлифованные с прямой канавкой

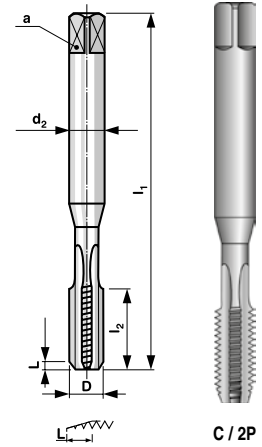
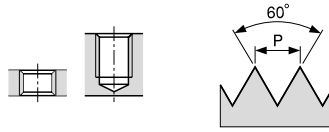

C / 2P

**M**  
Metrický závit  
Standard metric thread  
Metrische Regelgewinde  
Метрическая резьба

Lícování: ISO1 / Tolerance: ISO1 /  
Toleranz: ISO1 / Подгонка: ISO1

D	P	l <sub>1</sub>	l <sub>2</sub>	d <sub>2</sub>	a		code HSSE
M 3	0,5	48	11	3,15	2,5	2,50	162 030
M 4	0,7	53	13	4,0	3,15	3,30	162 040
M 5	0,8	58	16	5,0	4,0	4,20	162 050
M 6	1	66	19	6,3	5,0	5,00	162 060
M 8	1,25	72	22	8,0	6,3	6,80	162 080
M 10	1,5	80	24	10,0	8,0	8,50	162 100
M 12	1,75	89	29	9,0	7,1	10,20	162 120
M 14	2	95	30	11,2	9,0	12,00	162 140
M 16	2	102	32	12,5	10,0	14,00	162 160
M 18	2,5	112	37	14,0	11,2	15,50	162 180
M 20	2,5	112	37	14,0	11,2	17,50	162 200

**Materiál:** HSSE  
Provedení: broušený závit  
Závit: pravý

**Material:** HSSE  
Execution: ground thread  
Thread: right-hand

**Werkstoff:** HSSE  
Ausführung: geschliffenes  
Gewinde  
Gewinde: rechts

**Материал:** HSSE  
Изготовлено: шлифованная  
резьба  
Резьба: правая

# ČSN 22 3043

## HSSE

**Strojní závitníky** - broušený  
přímá drážka s lamačem třísek

**Machine taps** - grounded  
with spiral point

**Maschinen-Gewindebohrer** - geschliffen mit Schälanschnitt

**Механические метчики** - шлифованные с ломателем стружек

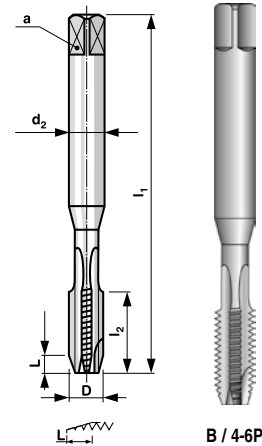
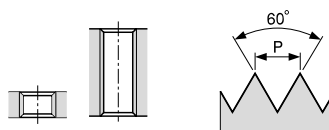

B / 4-6P

**M**  
Metrický závit  
Standard metric thread  
Metrische Regelgewinde  
Метрическая резьба

Lícování: ISO1 / Tolerance: ISO1 /  
Toleranz: ISO1 / Подгонка: ISO1

D	P	l <sub>1</sub>	l <sub>2</sub>	d <sub>2</sub>	a		code HSSE
M 3	0,5	48	11	3,15	2,5	2,50	163 030
M 4	0,7	53	13	4,0	3,15	3,30	163 040
M 5	0,8	58	16	5,0	4,0	4,20	163 050
M 6	1	66	19	6,3	5,0	5,00	163 060
M 8	1,25	72	22	8,0	6,3	6,80	163 080
M 10	1,5	80	24	10,0	8,0	8,50	163 100
M 12	1,75	89	29	9,0	7,1	10,20	163 120
M 14	2	95	30	11,2	9,0	12,00	163 140
M 16	2	102	32	12,5	10,0	14,00	163 160
M 18	2,5	112	37	14,0	11,2	15,50	163 180
M 20	2,5	112	37	14,0	11,2	17,50	163 200

**Materiál:** HSSE  
Provedení: broušený závit  
Závit: pravý

**Material:** HSSE  
Execution: ground thread  
Thread: right-hand

**Werkstoff:** HSSE  
Ausführung: geschliffenes  
Gewinde  
Gewinde: rechts

**Материал:** HSSE  
Изготовлено: шлифованная  
резьба  
Резьба: правая

**BUČOVICE TOOLS a.s.**

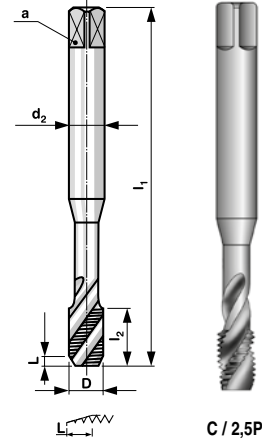
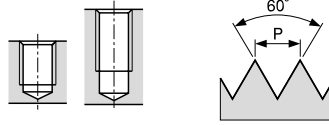

**PN 8/3044****HSSE****Strojní závitníky** - broušený  
se šroubovitými drážkami 35°**Machine taps** - grounded  
with spiral flute 35°**Maschinen-Gewinde-  
bohrer** - geschliffen mit  
Rechtsspiralnute 35°**Механические метчики**  
- шлифованные винтовыми дорожками 35°

C / 2,5P

**M** Metrický závit  
Standard metric thread  
Metrische Regelgewinde  
Метрическая резьба

Lícování: ISO1 / Tolerance: ISO1 /  
Toleranz: ISO1 / Подгонка: ISO1

D	P	l <sub>1</sub>	l <sub>2</sub>	d <sub>2</sub>	a		code HSSE
M 3	0,5	48	5,5	3,15	2,5	2,50	164 030
M 4	0,7	53	8	4,0	3,15	3,30	164 040
M 5	0,8	58	9	5,0	4,0	4,20	164 050
M 6	1	66	11	6,3	5,0	5,00	164 060
M 8	1,25	72	14	8,0	6,3	6,80	164 080
M 10	1,5	80	16	10,0	8,0	8,50	164 100
M 12	1,75	89	20	9,0	7,1	10,20	164 120
M 14	2	95	30	11,2	9,0	12,00	164 140
M 16	2	102	32	12,5	10,0	14,00	164 160
M 18	2,5	112	37	14,0	11,2	15,50	164 180
M 20	2,5	112	37	14,0	11,2	17,50	164 200

Materiál: HSSE  
Provedení: broušený závit  
Závit: pravý

Material: HSSE  
Execution: ground thread  
Thread: right-hand

Werkstoff: HSSE  
Ausführung: geschliffenes  
Gewinde  
Gewinde: rechts

Материал: HSSE  
Изготовлено: шлифованная  
резьба  
Резьба: правая

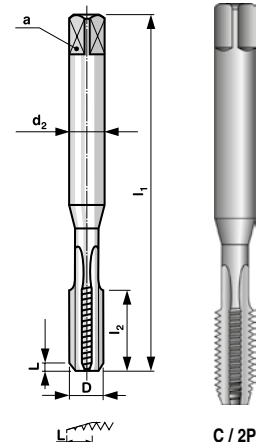
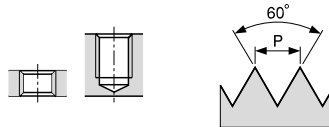
**DIN 371****HSSE****Strojní závitníky** - broušený  
s přímou drážkou**Machine taps** - grounded  
with straight flute**Maschinen-Gewinde-  
bohrer** - geschliffen mit gerade Nuten**Метчики**  
- шлифованные с прямой канавкой

C / 2P

**M** Metrický závit  
Standard metric thread  
Metrische Regelgewinde  
Метрическая резьба

Lícování: ISO2 (6H) / Tolerance: ISO2 (6H) /  
Toleranz: ISO2 (6H) / Подгонка: ISO2 (6H)

D	P	l <sub>1</sub>	l <sub>2</sub>	d <sub>2</sub>	a		code HSSE
M 3	0,5	56	11	3,5	2,7	2,50	172 030
M 4	0,7	63	13	4,5	3,4	3,30	172 040
M 5	0,8	70	16	6,0	4,9	4,20	172 050
M 6	1	80	19	6,0	4,9	5,00	172 060
M 8	1,25	90	22	8,0	6,2	6,30	172 080
M 10	1,5	100	24	10,0	8,0	8,50	172 100

**BUČOVICE  
TOOLS a.s.**

Materiál: HSSE  
Provedení: broušený závit  
Závit: pravý

Material: HSSE  
Execution: ground thread  
Thread: right-hand

Werkstoff: HSSE  
Ausführung: geschliffenes  
Gewinde  
Gewinde: rechts

Материал: HSSE  
Изготовлено: шлифованная  
резьба  
Резьба: правая

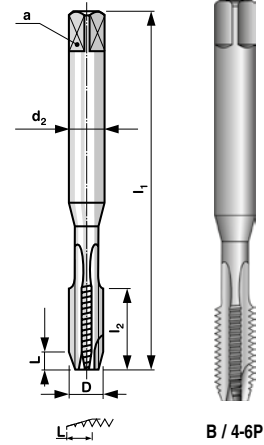
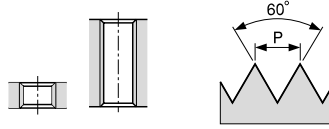
**DIN 371****HSSE****Strojní závitníky** - broušený  
přímá drážka s lamačem třísek**Machine taps** - grounded  
with spiral point**Maschinen-Gewinde-  
bohrer** - geschliffen mit Schälanschnitt**Механические метчики**  
- шлифованные с ломателем стружек

B / 4-6P

**M** Metrický závit  
Standard metric thread  
Metrische Regelgewinde  
Метрическая резьба

Lícování: ISO2 (6H) / Tolerance: ISO2 (6H) /  
Toleranz: ISO2 (6H) / Подгонка: ISO2 (6H)

D	P	l <sub>1</sub>	l <sub>2</sub>	d <sub>2</sub>	a		code HSSE
M 3	0,5	56	11	3,5	2,7	2,50	173 030
M 4	0,7	63	13	4,5	3,4	3,30	173 040
M 5	0,8	70	16	6,0	4,9	4,20	173 050
M 6	1	80	19	6,0	4,9	5,00	173 060
M 8	1,25	90	22	8,0	6,2	6,30	173 080
M 10	1,5	100	24	10,0	8,0	8,50	173 100

Materiál: HSSE  
Provedení: broušený závit  
Závit: pravý

Material: HSSE  
Execution: ground thread  
Thread: right-hand

Werkstoff: HSSE  
Ausführung: geschliffenes  
Gewinde  
Gewinde: rechts

Материал: HSSE  
Изготовлено: шлифованная  
резьба  
Резьба: правая

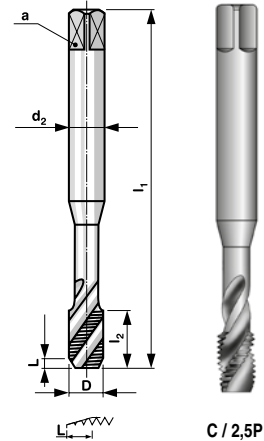
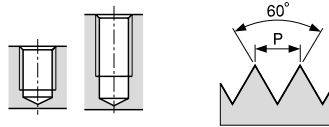
**DIN 371****HSSE****Strojní závitníky** - broušený  
se šroubovitými drážkami 35°**Machine taps** - grounded  
with spiral flute 35°**Maschinen-Gewinde-  
bohrer** - geschliffen  
mit Rechtsspiralnute 35°**Механические метчики**  
- шлифованные с винтовыми дорожками 35°

C / 2,5P

**M** Metrický závit  
Standard metric thread  
Metrische Regelgewinde  
Метрическая резьба

Lícování: ISO2 (6H) / Tolerance: ISO2 (6H) /  
Toleranz: ISO2 (6H) / Подгонка: ISO2 (6H)

D	P	l <sub>1</sub>	l <sub>2</sub>	d <sub>2</sub>	a		code HSSE
M 3	0,5	56	5	3,5	2,7	2,50	174 030
M 4	0,7	63	7	4,5	3,4	3,30	174 040
M 5	0,8	70	8	6,0	4,9	4,20	174 050
M 6	1	80	10	6,0	4,9	5,00	174 060
M 8	1,25	90	13	8,0	6,2	6,30	174 080
M 10	1,5	100	15	10,0	8,0	8,50	174 100

Materiál: HSSE  
Provedení: broušený závit  
Závit: pravý

Material: HSSE  
Execution: ground thread  
Thread: right-hand

Werkstoff: HSSE  
Ausführung: geschliffenes  
Gewinde  
Gewinde: rechts

Материал: HSSE  
Изготовлено: шлифованная  
резьба  
Резьба: правая

**BUČOVICE  
TOOLS a.s.**

# DIN 376

# HSSE

**Strojní závitníky** - broušený s přímou drážkou

**Machine taps** - grounded with straight flute

**Maschinen-**

**Gewindebohrer** - geschliffen mit gerade Nuten

**Метчики**

- шлифованные с прямой канавкой

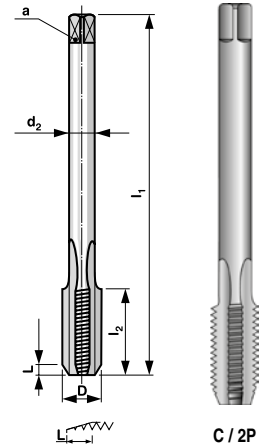
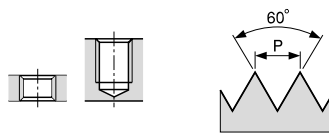

Metrický závit  
Standard metric thread  
Metrische Regelgewinde  
Метрическая резьба

Lícování: ISO2 (6H) / Tolerance: ISO2 (6H) /  
Toleranz: ISO2 (6H) / Подгонка: ISO2 (6H)

M

D	P	l <sub>1</sub>	l <sub>2</sub>	d <sub>2</sub>	a		code HSSE
M 12	1,75	110	28	9,0	7,0	10,20	182 120
M 14	2	110	30	11,0	9,0	12,00	182 140
M 16	2	110	32	12,0	9,0	14,00	182 160
M 20	2,5	140	34	16,0	12,0	17,50	182 200

Materiál: HSSE  
Provedení: broušený závit  
Závit: pravý

Material: HSSE  
Execution: ground thread  
Thread: right-hand

Werkstoff: HSSE  
Ausführung: geschliffenes  
Gewinde  
Gewinde: rechts

Material: HSSE  
Изготовлено: шлифованная  
резьба  
Резьба: правая

# DIN 376

# HSSE

**Strojní závitníky** - broušený přímá drážka s lamačem třísek

**Machine taps** - grounded with spiral point

**Maschinen-Gewinde-**

**bohrer** - geschliffen mit Schälanschnitt

**Механические метчики**

- шлифованные с ломателем стружек

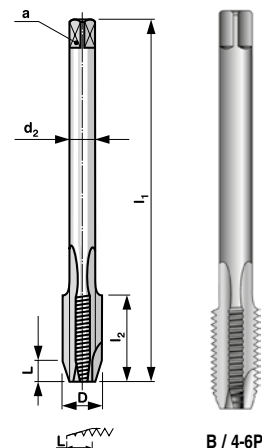
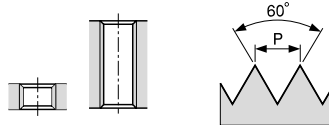

Metrický závit  
Standard metric thread  
Metrische Regelgewinde  
Метрическая резьба

Lícování: ISO2 (6H) / Tolerance: ISO2 (6H) /  
Toleranz: ISO2 (6H) / Подгонка: ISO2 (6H)

M

D	P	l <sub>1</sub>	l <sub>2</sub>	d <sub>2</sub>	a		code HSSE
M 12	1,75	110	28	9,0	7,0	10,20	183 120
M 14	2	110	30	11,0	9,0	12,00	183 140
M 16	2	110	32	12,0	9,0	14,00	183 160
M 20	2,5	140	34	16,0	12,0	17,50	183 200

Materiál: HSSE  
Provedení: broušený závit  
Závit: pravý

Material: HSSE  
Execution: ground thread  
Thread: right-hand

Werkstoff: HSSE  
Ausführung: geschliffenes  
Gewinde  
Gewinde: rechts

Material: HSSE  
Изготовлено: шлифованная  
резьба  
Резьба: правая



**BUČOVICE TOOLS a.s.**

# DIN 376

# HSSE

**Strojní závitníky** - broušený  
se šroubovitými drážkami 35°

**Machine taps** - grounded  
with spiral flute 35°

**Maschinen-Gewinde-  
bohrer** - geschliffen  
mit Rechtsspiralnute 35°

**Механические метчики**

- шлифованные с винтовыми дорожками 35°

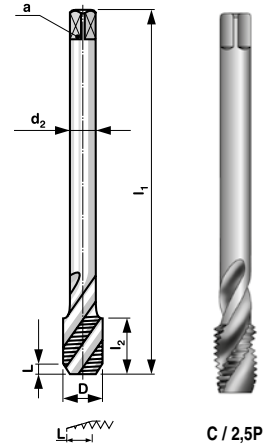
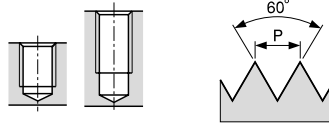

C / 2,5P

**M**  
Metrický závit  
Standard metric thread  
Metrische Regelgewinde  
Метрическая резьба

Lícování: ISO2 (6H) / Tolerance: ISO2 (6H) /  
Toleranz: ISO2 (6H) / Подгонка: ISO2 (6H)

D	P	l <sub>1</sub>	l <sub>2</sub>	d <sub>2</sub>	a		code HSSE
M 12	1,75	110	28	9,0	7,0	10,20	184 120
M 14	2	110	30	11,0	9,0	12,00	184 140
M 16	2	110	32	12,0	9,0	14,00	184 160
M 20	2,5	140	34	16,0	12,0	17,50	184 200

Materiál: HSSE  
Provedení: broušený závit  
Závit: pravý

Material: HSSE  
Execution: ground thread  
Thread: right-hand

Werkstoff: HSSE  
Ausführung: geschliffenes  
Gewinde  
Gewinde: rechts

Материал: HSSE  
Изготовлено: шлифованная  
резьба  
Резьба: правая

# HSS

**Kombinovaný závitník**  
**Combination taps**  
**Kombiniert**  
**Gewindebohrer**  
**Комбинируемый**  
**метчик**

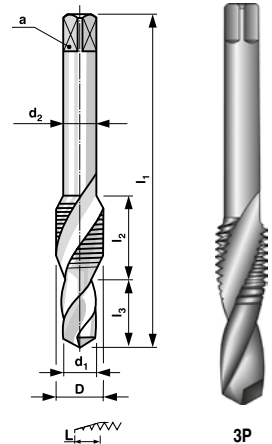
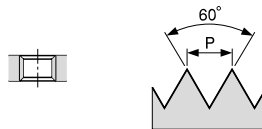

3P

**M**  
Metrický závit  
Standard metric thread  
Metrische Regelgewinde  
Метрическая резьба

Lícování: 2N / Tolerance: 2N /  
Toleranz: 2N / Подгонка: 2N

D	P	l <sub>1</sub>	l <sub>2</sub>	l <sub>3</sub>	d <sub>1</sub>	d <sub>2</sub>	a	code
M 4	0,7	50	13	10	3,3	4	3	133 040
M 5	0,8	56	15	12	4,2	5	3,8	133 050
M 6	1	64	17	14	5	6	4,9	133 060
M 8	1,25	72	12	20	6,8	8	6,2	133 080
M 10	1,5	80	14	22	8,5	10	8	133 100
M 12	1,75	90	16	25	10,25	12	9	133 120

Materiál: HSS  
Provedení: nebroušený závit  
Závit: pravý

Material: HSS  
Execution: non-ground thread  
Thread: right-hand

Werkstoff: HSS  
Ausführung: nicht  
geschliffenes Gewinde  
Gewinde: rechts

Материал: HSS  
Изготовлено:  
нешлифованная резьба  
Резьба: правая

**BUČOVICE  
TOOLS a.s.**